

TREX600P UNIVERSAL MOTOR MOUNT AND PINION SUPPORT AT600P-UMM (AL 6061-T6)

NOTE: FOR PROPER INSTALLATION OF THE SIDE RAILS, A MAXIMUM SCREW LENGTH OF 9MM IS ALLOWED FOR THE MOTOR MOUNT. APPROPRIATE M3 x 0.5 x 8MM FASTENERS HAVE BEEN PROVIDED FOR CORRECT INSTALLATION.

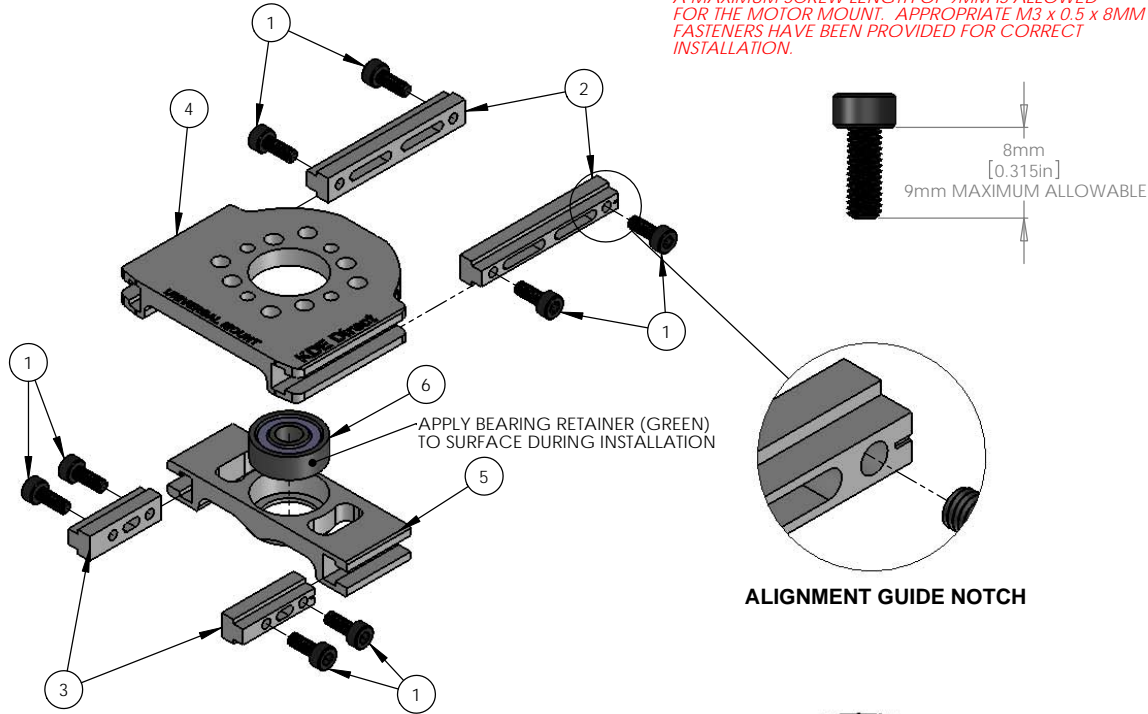

APPLY BEARING RETAINER (GREEN) TO SURFACE DURING INSTALLATION

ALIGNMENT GUIDE NOTCH

ITEM NO.	DESCRIPTION	QTY.
1	M3 x 0.5 x 8MM SOCKET HEAD CAP SCREW ALLOY STEEL	8
2	TREX 600P SERIES UNIVERSAL MOTOR MOUNT RAIL	2
3	TREX 600P SERIES UNIVERSAL PINION SUPPORT RAIL	2
4	TREX 600P SERIES UNIVERSAL MOTOR MOUNT PLATE	1
5	TREX 600P SERIES UNIVERSAL PINION SUPPORT PLATE	1
6	RADIAL BALL BEARING 606ZZ	1
7	KDE DIRECT 600XF-530 HP BRUSHLESS MOTOR, 530Kv (SHOWN FOR REFERENCE, SOLD SEPARATELY)	1
8	REVCO HARDENED STEEL PINION GEAR, 14T, 6MM (SHOWN FOR REFERENCE, SOLD SEPARATELY)	1
9	KDE DIRECT TREX 700 SERIES NYLATRON MAIN DRIVE GEAR (SHOWN FOR REFERENCE, SOLD SEPARATELY)	1
10	KDE DIRECT 550/600 SERIES T700 UNIVERSAL MAIN GEAR CASE (SHOWN FOR REFERENCE, SOLD SEPARATELY)	1

NOTE: THE UNIVERSAL MOTOR MOUNT COMPONENTS HAVE BEEN CNC MACHINED TO PRECISE TOLERANCES FOR ACCURATE ALIGNMENT AND PROPER OPERATION. WHEN INSERTING THE RADIAL BEARING INTO THE PINION SUPPORT PLATE, APPLY A LIGHT COATING OF BEARING RETAINER (LOCTITE 290 OR EQUIVALENT) TO THE OUTER SURFACE OF THE BEARING, ALIGN THE BEARING TO THE BORE ACCURATELY, AND THEN PRESS IN BY HAND. IF A PRESS-FIT IS REQUIRED, BE CAREFUL TO ONLY APPLY PRESSURE TO THE OUTER-EDGE OF THE BEARING TO PREVENT DAMAGE TO THE INTERNAL COMPONENTS.

WHEN INSTALLATING THE MOTOR MOUNT AND PINION SUPPORT RAILS, ORIENTATION NOTCHES HAVE BEEN PROVIDED ON THE TOP SURFACE OF EACH PIECE. THIS IS AN ALIGNMENT GUIDE AND THE NOTCH WILL FACE TOWARDS THE MAIN GEAR/MAIN SHAFT FOR PROPER INSTALLATION.

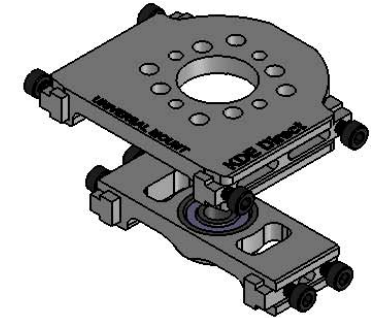
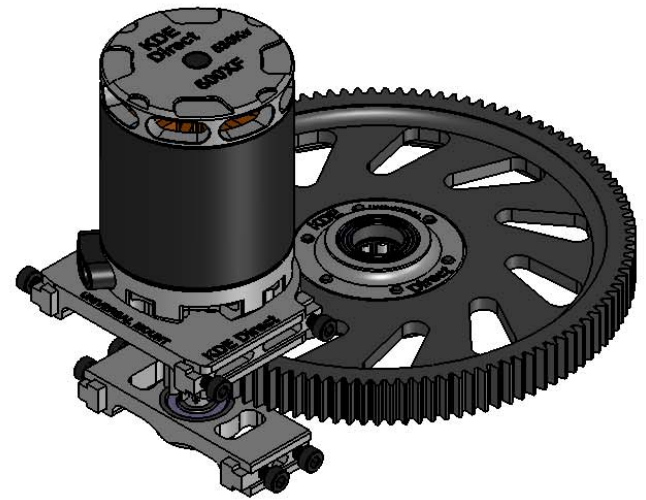
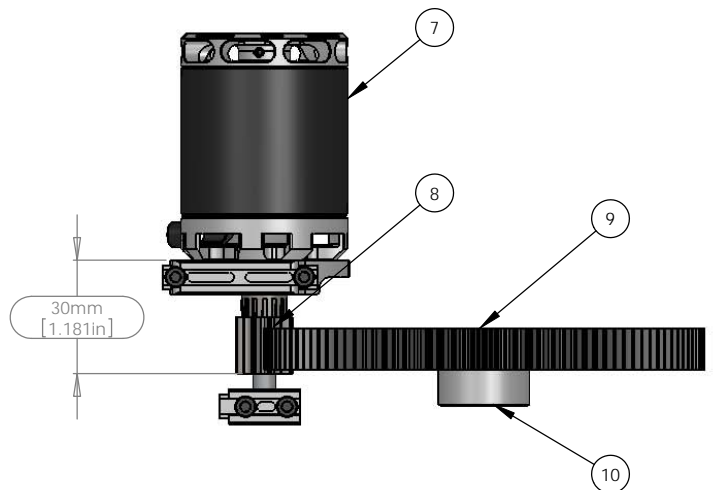

www.KDEDirect.com



www.KDEDirect.com
AT600P-UMM