

# DLE-120

## Operator's Manual

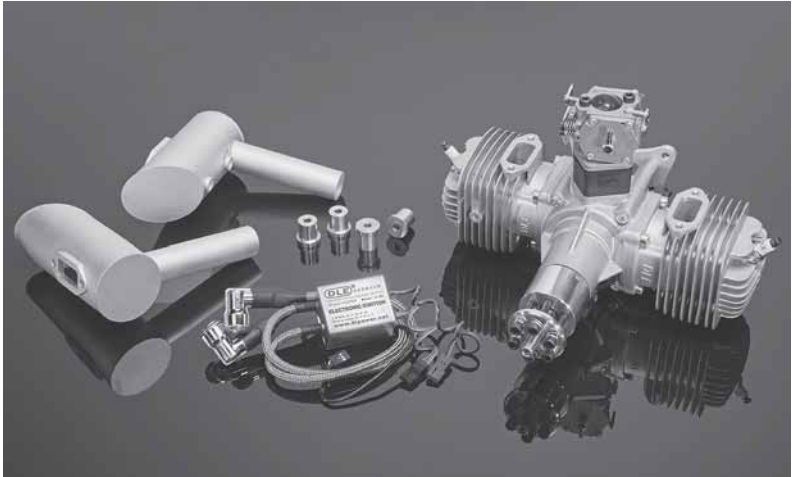

### Specifications

- Displacement:** 120cc 7.32 cu in  
**Performance:** 12 HP/7,500 RPM  
**Idle speed:** 1,300RPM  
**Ignition Style:** Electronic Ignition  
**Recommended Propellers:** 26×10, 26×12, 27×10, 28×10  
**Spark Plug Type:** NGK CM6  
(Gap) 0.018in. – 0.020 in. [0.45mm – 0.51mm]  
**Diameter x Stroke:** 1.85 in(47mm) x 1.38 in(35mm)  
**Compression Ratio:** 10.5: 1  
**Carburetor:** DLE with Manual Choke  
**Weight:** Main Engine – 5.08lb [2306g]  
Mufflers – 15.6oz [440g]  
Electronic Ignition – 6 oz [170g]  
Engine Mount Standoffs – 1.4 oz [41g]  
Fuel: 87– 93 Octane Gasoline with a 30:1  
**Fuel:** gas/2-stroke (2-cycle) oil mixture

**DLE**<sup>TM</sup>

## Parts List

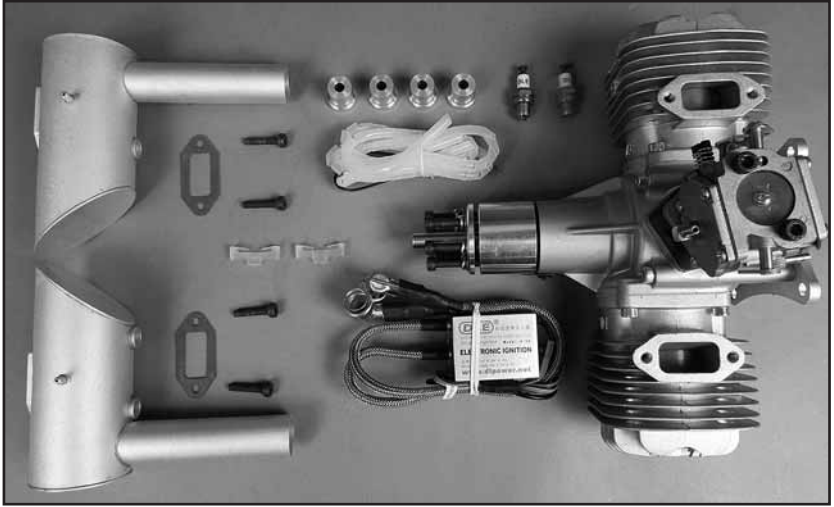

- (1) DLE-120 Gas Engine with DLE Carburetor
- (2) CM6 Spark Plugs with Spare Ignition Wire Springs
- (2) Mufflers w/Gaskets
- (4) 4x20mm SHCS (muffler mounting)
- (1) Electronic Ignition Module w/ Additional Tachometer Lead
- (4) 25mm Engine Mounting Standoffs
- (6) 5x50mm SHCS with 4mm Lock Washers & Flat Washers (propeller mounting)
- (1) Silicone Pick-up Wire Cover / Ignition Wire Cover
- (1) Red Three Pin Connector Lead w/ Pig Tail (for ignition switch)
- (2) Three Pin Connector Securing Clips
- (1) DLE Decal (not pictured)

## Safety Tips and Warnings

- This engine is not a toy. Please place your safety and the safety of others paramount while operating. DLE will not be held responsible for any safety issues or accidents involving this engine.
- Operate the engine in a properly ventilated area.
- Before starting the engine, please make sure all components including the propeller and the engine mount are secure and tight. It is strongly recommended that a screw sealant is used (Great Planes Threadlocker GPMR6060) during engine installation.
- During the break-in period, it is recommended that the engine be installed on the aircraft or a test stand with an appropriate shock absorber. Otherwise it is probable that vibration could rebound

back to the engine and serious damages may occur during the break-in period. Break-in should be considered about the first 3-5 gallons you run in the engine.

- For your safety and the safety of others, please do not stand in front of the propeller or inline with the propeller when the engine is running. Keep onlookers away from the running engine, especially small children.
- Always use a balanced spinner and a balanced propeller. An unbalanced spinner or propeller combination will cause high levels of vibration and may cause the propeller shaft to break. Always use a lightweight, high quality spinner on your engine. Heavy spinners could cause the propeller shaft to break. Evenly and securely tighten the spinner and propeller to the engine to prevent them from being thrown off the engine while running.
- Never use a propeller that has hit the ground. Even though it may look good from the outside, it may be cracked on the inside which may cause it to disintegrate while in use. Do not use a nicked, cracked or split propeller.
- Keep foreign objects away from the propeller. Make sure that nothing can be "sucked in" by the propeller.
- Never start the engine on loose gravel or sand.
- Do not attempt to stop the engine by throwing anything into the path of the propeller.
- Do not use silicone fuel line because it will be dissolved by the fuel. Use gasoline approved rubber fuel line. Always secure the fuel line away from the cylinder head. The engine's heat can damage the fuel line.
- Never touch the engine immediately after a run. The engine will be hot.
- Before transporting your model, remove all the fuel from the fuel tank and fuel lines.
- Always use high-quality oil intended for 2-stroke (2-cycle) engines. It's a good idea to use a petroleum-based 2-cycle motor oil like Lawn Boy All Season - Ashless oil for the break-in period.
- Do not install your throttle servo inside the engine compartment. Doing so could cause radio interference. When practical, install all electronic radio devices at least 12" [305mm] away from the engine.
- The throttle and choke pushrods should be non-metallic.
- If the engine is not to be used for more than a month, drain the fuel tank and remove any fuel from inside the carburetor. Do this by running the engine at idle until it quits by running out of fuel.

Keeping gasoline inside the carburetor over an extended period of time will damage the diaphragm valve and clog passages inside the carburetor. Because the carburetor is more complicated than those used in glow engines, keep the fuel clean by using a fuel filter. Use a filter intended to be used with gasoline engines. Metal filters intended for glow engine are too coarse and will not screen out finer particles.

- Always filter your fuel by using an appropriate filter before putting it into the airplane's fuel tank.
- Gasoline is extremely flammable. Keep it away from an open flame, excessive heat or sources of sparks.
- Do not smoke near the engine or the fuel tank.
- This engine was designed for use in a model aircraft. Do not attempt to use it for any other purpose.
- Always install an ignition system on/off switch on the aircraft used.
- **Caution:** Running the engine with a lean fuel mixture will cause the engine to overheat and burn the electrode of the spark plugs. Pay close attention to the High-speed Needle adjustment. Running the engine with the proper fuel mixture will make the spark plugs appear yellow at the ignition point.
- For optimum performance please use fresh or recently purchased 87-93 octane gasoline with a 30:1 fuel/oil mixture.

### ***Fuel/Oil Mixing Chart***

1 Gallon Gasoline (128 fl oz/3.78L) / 2-Cycle Oil  
(4.26fl oz/125.68ml) = 30:1 ratio

- Excessive running of the engine at idle speed can result in carbonized spark plugs.
- Keep the surface of the engine clean to ensure proper heat dissipation. Ensure proper cooling/ventilation around both cylinders with adequate air exhaust.
- To avoid permanent damage to the electronic ignition system, NEVER rotate the propeller on your DLE engine with the electronic ignition system switched on and the plug not installed in the plug cap.
- If you choose to use the optional TX activated Gas Engine Kill Switch (DLEG9205) it is strongly recommended that you install the TX activated kill switch between the on/off switch and the ignition. The on/off switch provides an added safety feature in the event the TX activated kill switch does not function properly. This is especially important during the starting sequence as it requires the on/off switch to be in the ON position before ignition can occur.

## Installation Instructions

### *Prepare the engine for installation*

1. Check to see that all screws and bolts are tight. Check carefully for any cracks, broken or missing parts. Tighten or replace any damaged or missing parts before proceeding.

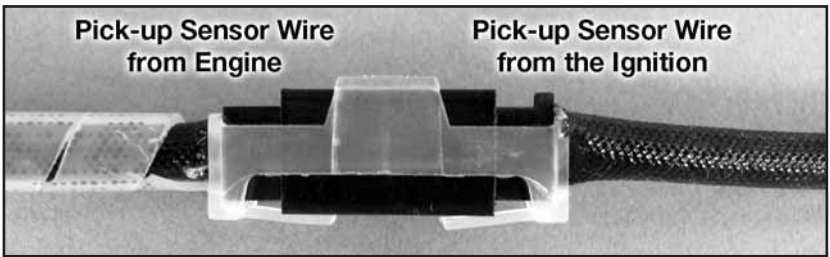

2. Install the silicone wire cover over the pick-up lead coming from the engine (cut the excess silicone wire cover) and connect the lead to the pick-up lead from the Electronic Ignition Module. Secure the connection with the included three pin connection securing clips.

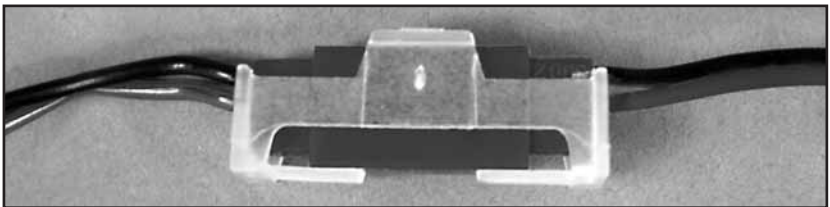
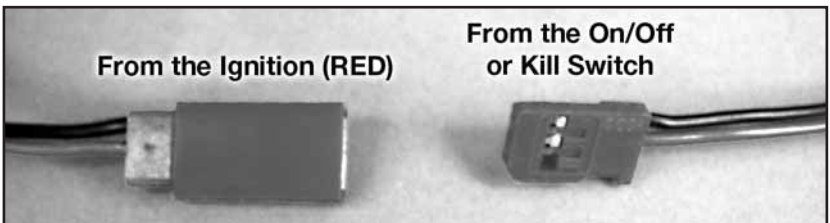

3. Connect the on/off switch lead to the red connector from the Electronic Ignition Module using the lead from the on/off switch or with the included three pin connector with pigtail. Use one of the included three pin securing clips to secure the connection.

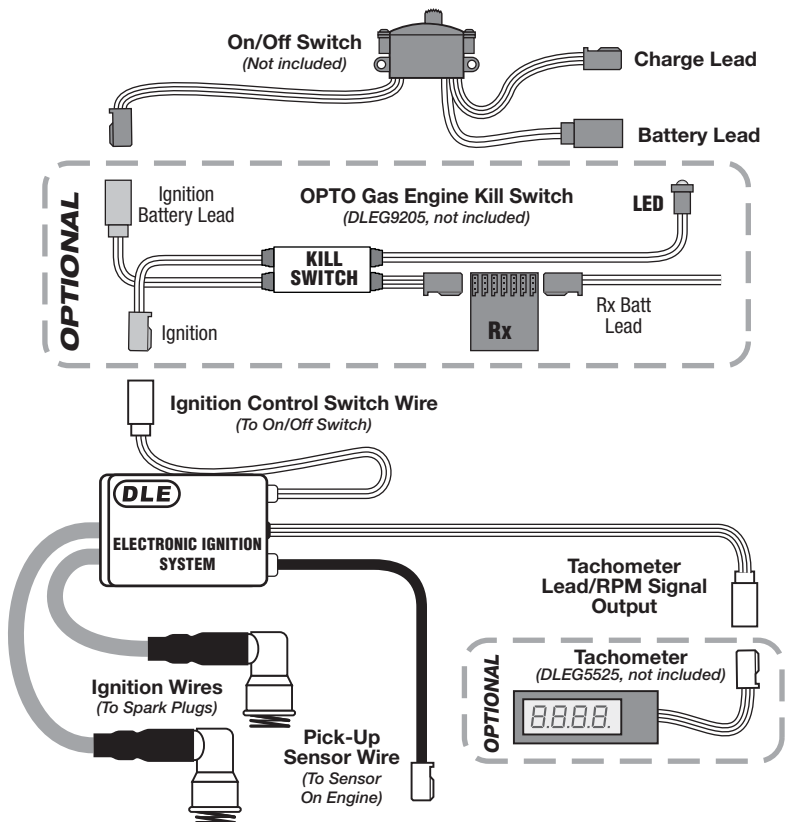

4. Connect the ignition module battery to the on/off switch. Any 4.8-8.4V, 1000mAh and above capacity battery will work well for this. Use heat shrink tubing to secure this connection. **Optional:** Install the TX activated gas engine kill switch (DLEG9205) between the on/off switch and the ignition as shown above. This is especially important during the starting sequence as it requires the on/off switch to be in the ON position before ignition can occur. The kill switch LED should be installed on the exterior of the aircraft so that it's visible from the front of the aircraft. This is to ensure that the person starting the engine is aware that the ignition is armed. If properly installed as shown above an illuminated red LED indicates that that the ignition is armed.

5. Install the ignition on/off switch on the aircraft so that it is easily accessible.



6. Install the ignition module and battery securely in the airplane forward area. It is recommended that a thin piece of foam rubber is placed between the module and the mounting surface and that Velcro® strap is used to hold the module in place.

7. Secure all connections with heat shrink tubing. (not supplied).
8. Install the remaining silicone wire covers over the ignition wires.
9. Install the spark plugs into the cylinders (7-8lbs torque). Do not overtighten.

### ***Installing the DLE-120 on Your Airplane***

**Note:** The DLE-120 must be installed on a minimum 3/8" [9.5mm] plywood firewall. The firewall must be securely glued to the airplane. Use triangle stock and pin the firewall with hardwood dowels to reinforce the firewall glue joints. Never install the DLE-120 onto a firewall thinner than specified because it may fail due to the power of the engine.

**Note:** The overall length of the engine from the back of the engine mount to the face of the propeller drive hub is 7.32" [186 mm].

1. Use the supplied template (on the back cover of this manual) to drill the engine mounting bolt holes.

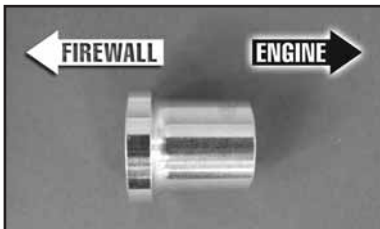

2. Install (4) 5mm blind nuts (not included) into the back side (non-engine side) of the firewall. Install the engine to the firewall using (4) 5x45mm SHCS with 5mm lock washers and flat washers (not included) with the included standoffs. Use threadlocking

compound, such as Great Planes® Pro™ Threadlocker (GPMR6060), on the screws where they thread into the blind nuts.

3. Install the fuel tank in the airframe. Use only 1/8" [3.175 mm] gasoline-safe fuel lines and a gasoline safe fuel tank stopper. One line should go to the carburetor (see page 14, *Fuel Inlet*) and the other is to be used as a vent (a vent line is simply an open ended fuel line from the fuel tank which exits the engine compartment or the fuselage; most vent lines exit at the bottom of the firewall). You can fill the tank by using the carburetor line as fill line if you have access to it or install a third line to be used as fill line. Installing a third line is the cleanest and easiest way to add fuel. An alternative fueling set up is a 2-line system with a T-fitting approved for gasoline use. Be sure to use a filler plug with either a 2 line or 3 line set-up. It is a good idea to add an extension to the vent line as shown, that goes up and to the rear of the tank. This helps to avoid draining fuel from the tank when the model is pointed down.

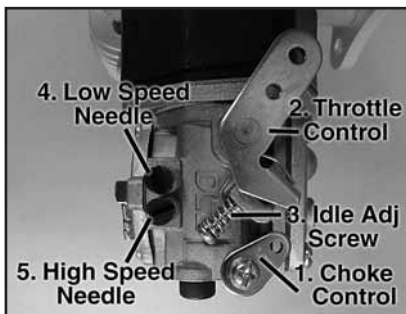
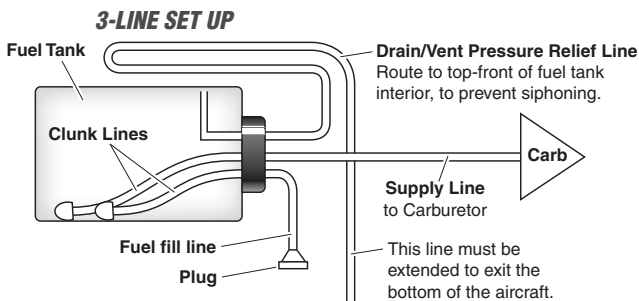
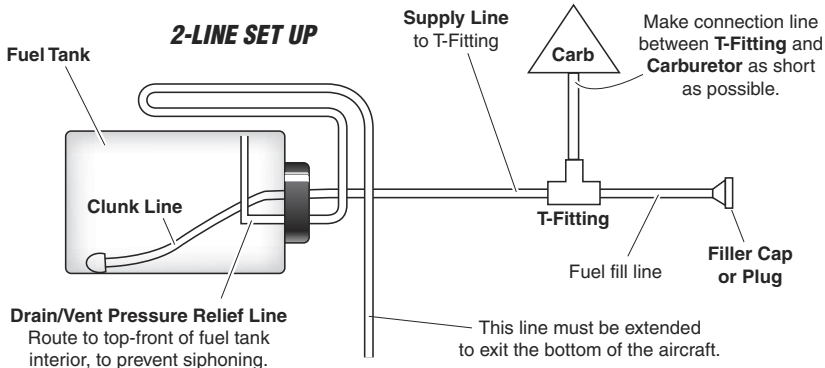

4. Install the throttle servo at least 12" [305mm] away from the engine. Make sure that you get the carburetor's full range of rotation with your servo travel. Be sure to use a non-metallic linkage (as shown below). A high torque metal gear servo is recommended to operate the throttle. Install a ball link and lock nut on the throttle arm (available at your local hobby shop). Next, install the linkage from the servo to the throttle arm. Removal of the throttle return spring is optional. Removing the spring reduces the load on the throttle servo, but also bypasses a necessary safety feature. Remove the throttle return spring at your own risk.

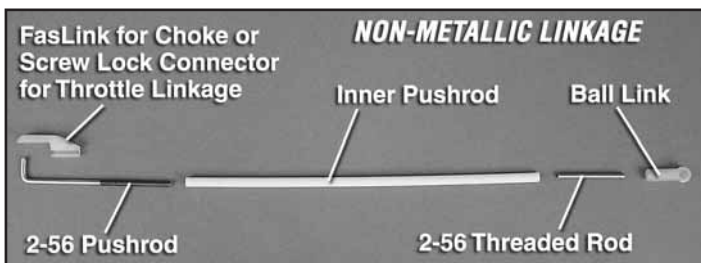





**5.** Install the choke servo (optional) at least 305mm [12"] away from the engine. Be sure to use a non-metallic linkage. Install a ball link and lock washers to the choke arm (available at your local hobby shop). Next, install the linkage from the servo to the choke arm.

**6.** Connect the ignition wires from ignition module to the spark plugs.

**7.** Install the mufflers onto the engine. Be sure to use threadlocker, and that the ignition wires do not contact the mufflers.

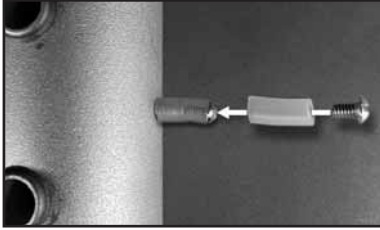

**8.** If not being used, plug the smoke fittings on the mufflers with a segment of fuel tubing and an 8-32 screw (not included).

**9.** Cut all necessary clearance, cooling, carburetor adjustment, and exhaust holes in the cowl.

**10.** Ensure the sensor wire is supported as close to the sensor pick-up as possible. Flight loads may cause stress and damage to the wire where it enters the sensor body.

**11.** Make sure the cowl is secured to the airplane and that the spinner back plate to cowl clearance is at least 1/8" [3.2mm]. When starting the engine for the first time and during break-in, it's recommended that you run the engine without the cowling.

## Drilling the Propeller

The easiest way to drill the propeller to fit the hub is to use a DLE drill guide (DLEQ1111). If you do not have a drill guide, you can use the following method to drill your propellers. Most propellers within the recommended size range have a 0.393" [10mm] center hole pre-drilled. If your propeller has this predrilled hole, move on to step 3. If not, start with step 1.

**1.** Remove the cowling from the aircraft. Use the included propeller washer to mark the centering hole on the propeller.



**2.** Once the location is established, use a drill press with a #5 (.2055" / 5.21mm) drill bit as a pilot hole. Once the pilot hole is established use a 13/32" (.406/10.31mm) drill bit to finish the hole. In order to achieve a clean opening on both sides of the propeller, drill only

half way through the propeller with the finishing drill bit. Then flip the propeller over and drill completely through the hole.



**3.** Next, set the engine at the beginning of the compression stroke. Note the position of the ignition magnet.

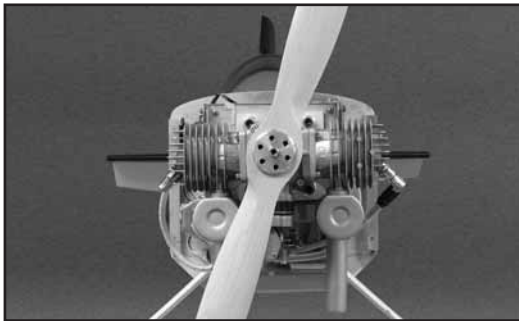

**4.** Place the propeller on the crankshaft at the one o'clock position.

**5.** Mark the location of one of the outer holes. Use a GPM Dead Center Hole Locator (GPMR8130) to center and start the hole.

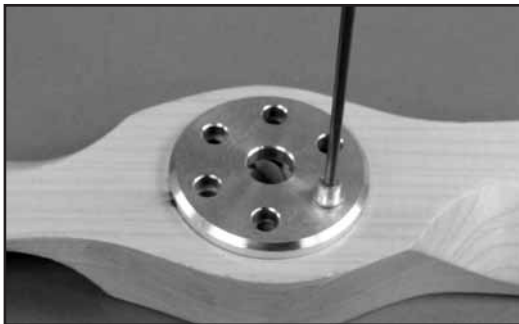

**6.** Remove the propeller from the engine and drill the outer hole using a #35 drill bit as a pilot hole. Next use a #5 (.2055" / 5.21mm) drill bit to finish the hole. In order to achieve a clean opening on both sides of the propeller, drill only half way through

the propeller with the finishing drill bit. Then flip the propeller over and drill completely through the hole.

**7.** Use one of the 5x50mm SHCS with 5mm lock washers and flat washers to align the propeller washer on the propeller and use the Dead Center Hole Locator to mark the position of the remaining five holes.

**8.** Drill the remaining five holes in the propeller.

**9.** Securely mount the propeller to the engine using the 5x50mm SHCS with 5mm lock washers and flat washers. Be sure to use threadlocker.

## Starting Procedures

There are two recommended ways to start the DLE-120:

### A. Manual Starting

**Note:** When hand starting the DLE-120, use a thick glove or heavy duty starter stick to protect your hand.

1. The propeller should be installed on the drive washer so that it is at the one o'clock position and at the beginning of the compression stroke so that it is comfortable to flip it through compression.
2. Have someone help you hold the airplane while you start the engine.
3. Close the choke on the carburetor and open the throttle slightly from the idle position.
4. Switch on, or power your radio system and make sure you have control of the throttle visually at the carburetor. Also make sure that the reversing position of the servo is correct at the transmitter and that the throttle is at the minimum position.
5. Switch the ignition to ON. If you installed the optional TX activated gas engine kill switch (DLEG9205) properly between the on/off switch and the ignition make sure that the TX switch assigned is in the on position. The LED should be illuminated red to indicate that the ignition is armed.
6. Flip the propeller *counter clockwise* several times briskly.
7. After you hear some initial firing sounds, move the choke lever to the OPEN position.
8. Set the throttle to a high idle. Set the propeller so that it's at the beginning of the compression stroke
9. Flip the propeller through compression rapidly. If this is done properly, the engine will start after several brisk flips of the propeller.
10. After starting, let the engine idle for 30 to 45 seconds. Open and close the throttle slowly until the engine runs smoothly at idle and at full throttle. Acceleration should also be smooth. If acceleration is not smooth adjustments to the carburetor may be necessary. (See **Adjustment of the Engine** on page 14.)
11. If your engine does not start, repeat steps 6 through 10.

## ***B. Electric Starter Starting***

1. A 24 volt electric starter is recommended to start the DLE-120. Make sure you use a high quality, lightweight aluminum spinner.
2. Have someone help you hold the airplane while you start it.
3. Close the choke on the carburetor and open the throttle slightly from the idle position.
4. Switch on, or power your radio system and make sure you have control of the throttle visually at the carburetor. Also make sure that the reversing position of the servo is correct at the transmitter and that the throttle is at the minimum position.
5. Switch the ignition to ON. If you installed the optional TX activated gas engine kill switch (DLEG9205) properly between the on/off switch and the ignition make sure that the TX switch assigned is in the on position. The LED should be illuminated red to indicate that the ignition is armed.
6. Using the starter, turn over the engine till popping sound is heard. Next, open the choke.
7. Use your electric starter to turn over the engine until it starts.
8. After starting, let the engine idle for one to two minutes. Open and close the throttle slowly until the engine runs smoothly at idle and at full throttle. Acceleration should also be smooth. If acceleration is not smooth, adjustments to the carburetor may be necessary. (See **Adjustment of the Engine** on pages 10–12.)
9. If your engine does not start, repeat steps 6 and 7.

## Engine Troubleshooting

Symptom	Diagnosis	Fix
Engine does not fire	Ignition battery voltage low	Charge or replace battery
	Battery wires faulty or loose	Replace wires or Re-connect/check connections
	Fouled or faulty spark plug, not firing	Replace spark plug or check for spark *
	Engine flooded	Remove plug, disconnect fuel line, rotate prop to remove fuel
Engine starts, then rpm increases till engine cuts out	Fuel not reaching engine	Check for: a) fuel in tank b) fuel tubing cut, blocked, or kinked c) carburetor clogged

\*This can be done by removing the spark plug from the cylinder of the engine, inserting the plug into the plug cap and contacting the plug to the outside of the crankcase or cylinder. Have an assistant turn the engine over while checking this and be sure to have the spark plug firmly plugged into the ignition wire. **Warning:** The high voltage from the ignition can cause bodily harm, especially when checking for spark in this manner.

## Adjustment of the Engine

Each DLE has been factory preset. However, higher elevations will influence the performance of the carburetor. To obtain optimum output of the engine, slight adjustment of the carburetor may be necessary.

For safety reasons, do not make adjustments to the carburetor during operation.

### Functions and Adjustments

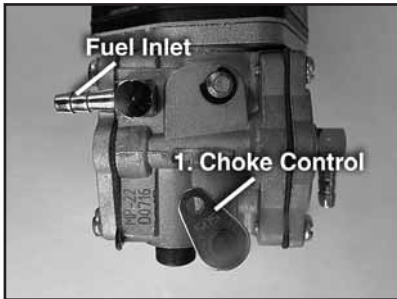

1. Choke Control (the choke control is used under the circumstance of cold start-up)
2. Throttle Control
3. Idle Adjustment Screw (adjust the idle speed)
4. (L) Low-speed Needle (adjusts the fuel/air mixture at low speeds)
5. (H) High-speed Needle (adjusts the fuel/air mixture at high speeds)

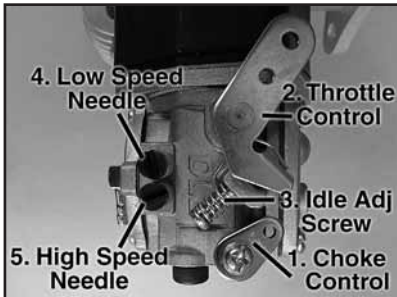

### Idle Adjustment

Turning the Idle Adjustment Screw (No.3) clockwise will increase the idle speed. Turning the Idle Screw counter-clockwise will decrease the idle speed.

### Low Speed Needle Adjustment

Turning the Low-speed Needle (No.4) clockwise will lean the fuel/air mixture at low speeds. Turning the Low-speed Needle (No.4) counter-clockwise will richen the fuel/air mixture at low speeds. (The default or factory setting of the Low-speed Needle is as follows: turn the needle to the fully closed position and then open the needle 1.25 turns)

### High Speed Needle Adjustment

Turning the High-speed Needle (No.5) clockwise will lean the fuel/air mixture at high speeds. Turning the High-speed Needle (No.5) counter-clockwise will richen the fuel/air mixture at high speeds. (The default or factory setting of the High-speed Needle is as follows: turn the needle to the fully closed position and then open the needle 1.5 turns). It is recommended that the High-speed Needle be adjusted by the use of a tachometer to obtain maximum speed.

Smooth acceleration and deceleration is an indicator of proper engine performance.

## Ignition Timing Adjustment

The ignition timing is preset on the DLE-120 at 44° before Top Dead Center (TDC). The ignition timing can be advanced or retarded slightly by loosening the (2) ignition sensor phillips head screws and sliding the sensor to the full extent clockwise (45° advancing the ignition) or counter clockwise (43° retarding the ignition). Be sure to retighten the phillips head screws after adjusting the ignition timing.

**Advancing the timing causes combustion to occur earlier resulting in higher performance of the engine. However, advancing the timing also causes higher engine temperatures and can cause premature wear of internal engine components.**

## Carburetor Adjustment Troubleshooting

### **Problem:**

- If* The engine hesitates when accelerated rapidly.
- or* The rpm increases at idling.
- or* The engine stops when the throttle is moved from high to low.

### **Solution:**

The low-speed needle "L" is too lean. Open it up about 1/8 of a turn and try again.

---

### **Problem:**

- If* The idle is not steady.

### **Solution:**

The low-speed needle "L" valve is too rich. Close it 1/8 of a turn and try again.

---

### **Problem:**

- If* Engine stops at full throttle.
- or* Engine hesitates when accelerated rapidly.
- or* The engine will not come up to full rpm at full throttle.

### **Solution:**

The high-speed needle valve "H" is too lean. Open it up 1/8 of a turn and try again.

---

### **Problem:**

- If* Your engine does not reach full rpm.
- or* Carbon build-ups appear consistently on your spark plug.

### **Solution:**

The high-speed needle valve "H" is too rich. Close it up 1/8 turn and try again.

## Optional Digital Tachometer



An optional Digital Tachometer (DLEG5525) is available that can be directly connected to the ignition and display the RPMs of the engine. This unit can be permanently installed on the aircraft or used to spot check the Engine RPMs. Do not

install or uninstall the Digital Tachometer while the engine is running.

Many of the DLE Ignition modules have an additional lead to plug into the optional tachometer. If your ignition module does not have this additional lead, the digital tachometer can still be used. Simply use the Y-harness (included with the Digital Tachometer) to connect to the pick-up lead from the engine. Be sure to secure all connections and to secure the Digital Tachometer or leads on the aircraft used.

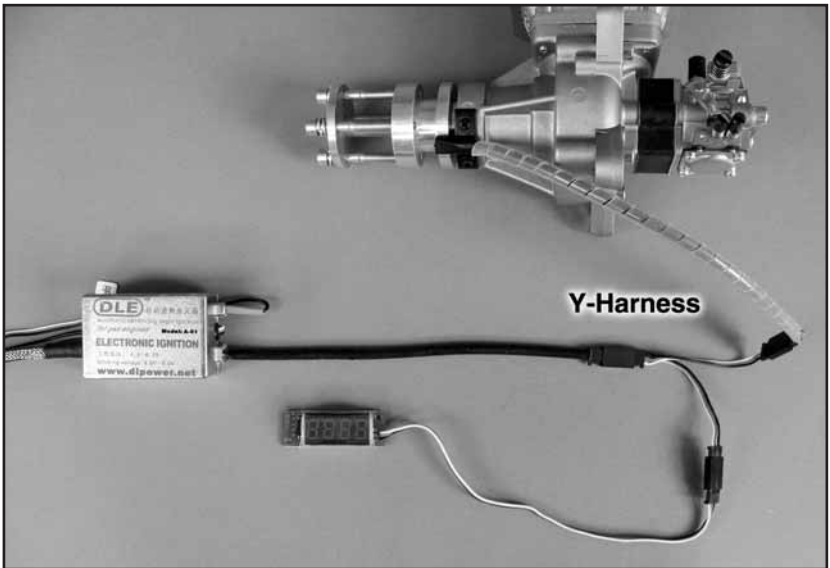



## Engine Maintenance

Please clean the non-removable fuel filter in the carburetor periodically. Failure to do so may result in mis-calibration of the needle adjustments. In order to do this it is necessary to remove the phillips head screw which secure the carb filter cover and the carburetor filter gasket. Use only carburetor cleaner to spray around the opening of the filter.

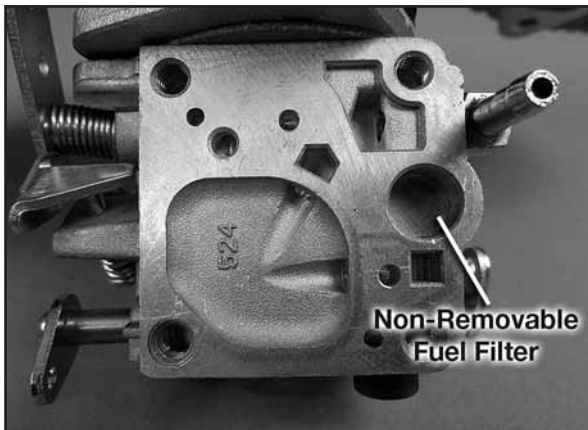
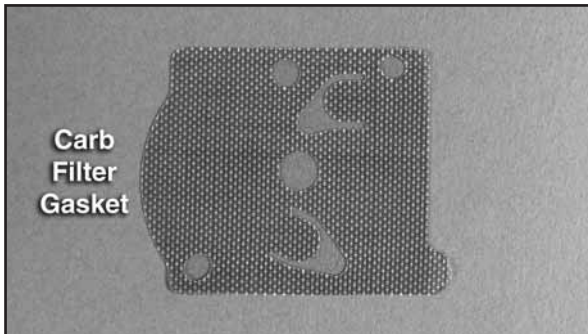

## Warranty Information

The DLE-120 has a two year limited warranty through Hobby Services beginning at date of purchase. Please retain your receipt as your proof of purchase.

## Contact Us

### Hobby Services

3002 N. Apollo Drive Suite #1  
Champaign, IL 61822

Tel: 217-398-8970

Fax: 217-398-7721

E-mail: [www.enginesupport@Hobbico.com](mailto:www.enginesupport@Hobbico.com)

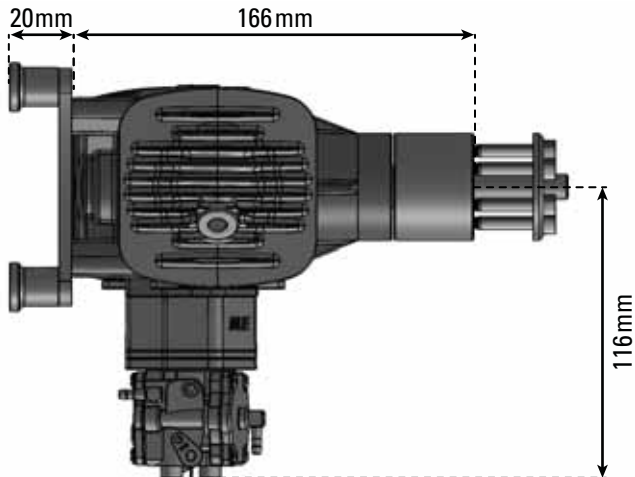
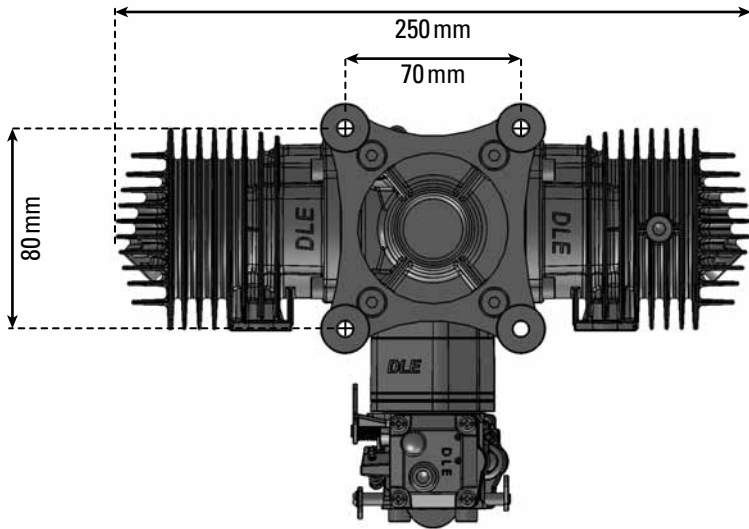



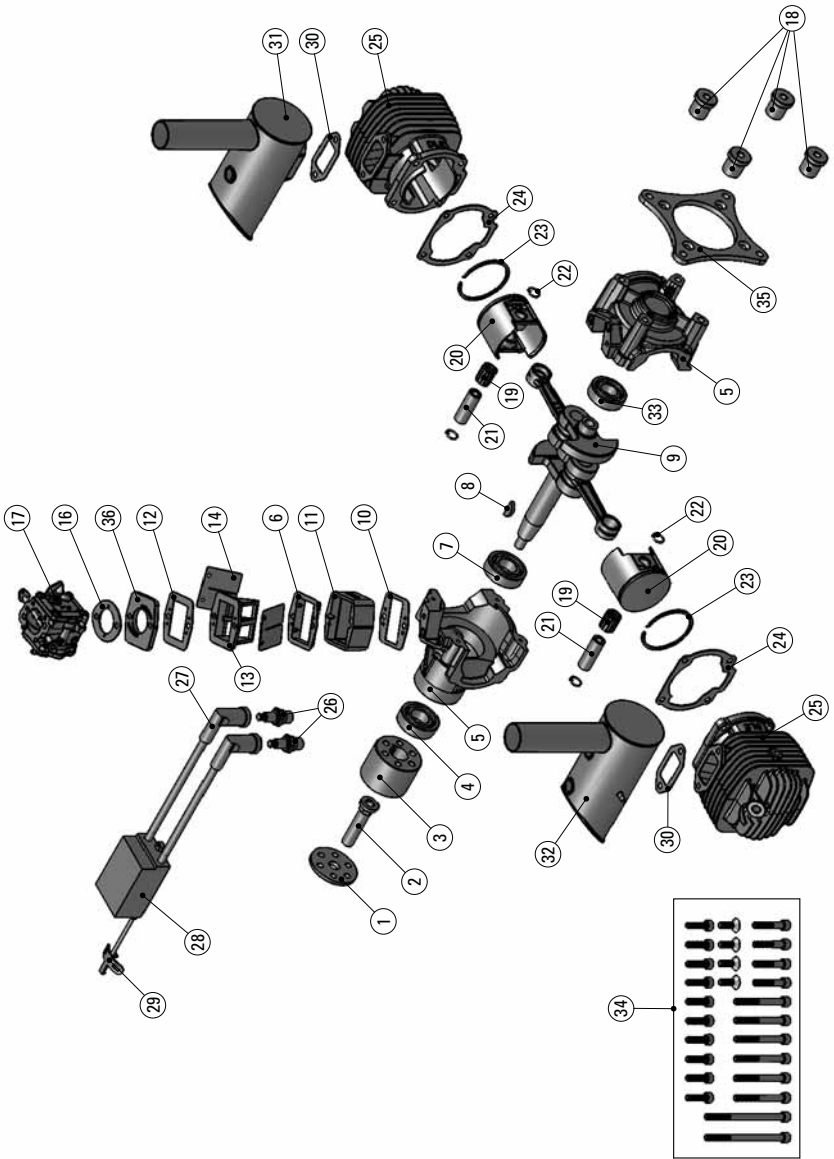

## Stock Number/Key Numbers

Key No.	Stock No.	Mfg Stock No.	Description
1	DLEG1301	120-Y1	Prop Washer
2	DLEG1302	120-Y2	Prop Drive Hub Nut
3	DLEG1303	120-Y3	Prop Drive Hub
4	DLEG1304	120-Y4	Bearing Front
5	DLEG1305	120-Y5	Crankcase
6	DLEG1306	120-Y6	Crankshaft Spacer
7	DLEG1307	120-Y7	Bearing Middle
8	DLEG1308	120-Y8	Woodruff Key
9	DLEG1309	120-Y9	Crankshaft
10	DLEG1310	120-Y10	Gasket Set
12			
16			
24			
30			
11	DLEG1311	120-Y11	Carb Heat Block
13	DLEG1313	120-Y13	Reed Valve Assembly
14	DLEG1314	120-Y14	Reed Valve Petals
17	DLEG1317	120-Y17	Reed Valve Plates
18	DLEG1318	120-Y18	Carb Complete
19	DLEG1319	120-Y19	Engine Mount Standoffs
20	DLEG1320	120-Y20	Needle Bearing
21	DLEG1321	120-Y21	Piston w/Pin/Retainer
22	DLEG1322	120-Y22	Piston Pin
23	DLEG1323	120-Y23	Piston Pin Retainer
25	DLEG1325	120-Y25	Piston Ring
26	DLEG1326	120-Y26	Cylinder w/Gasket
27	DLEG1327	120-Y27	Spark Plug
28	DLEG1328	120-Y28	Spark Plug Cap
29	DLEG1329	120-Y29	Electronic Ignition #2
31	DLEG1331	120-Y31	Ignition Sensor
32	DLEG1332	120-Y32	Muffler Left 1-Hole
33	DLEG1333	120-Y33	Muffler Right 2-Hole
34	DLEG1334	120-Y34	Bearing Rear
35	DLEG1335	120-Y35	Screw Set
36	DLEG1336	120-Y36	Carburetor Base

### Optional Parts (not shown)

DLEG5525	Onboard Digital Tachometer
DLEG9010	Tuned Exhaust Header
DLEG9011	Tuned Exhaust Canister
DLEG9012	Tuned Exhaust Complete
DLEG9205	OPTO Gas Engine Kill Switch
DLEQ1111	Prop Drill Guide 85, 111, 120





## DLE-120 Twin Mounting Pattern

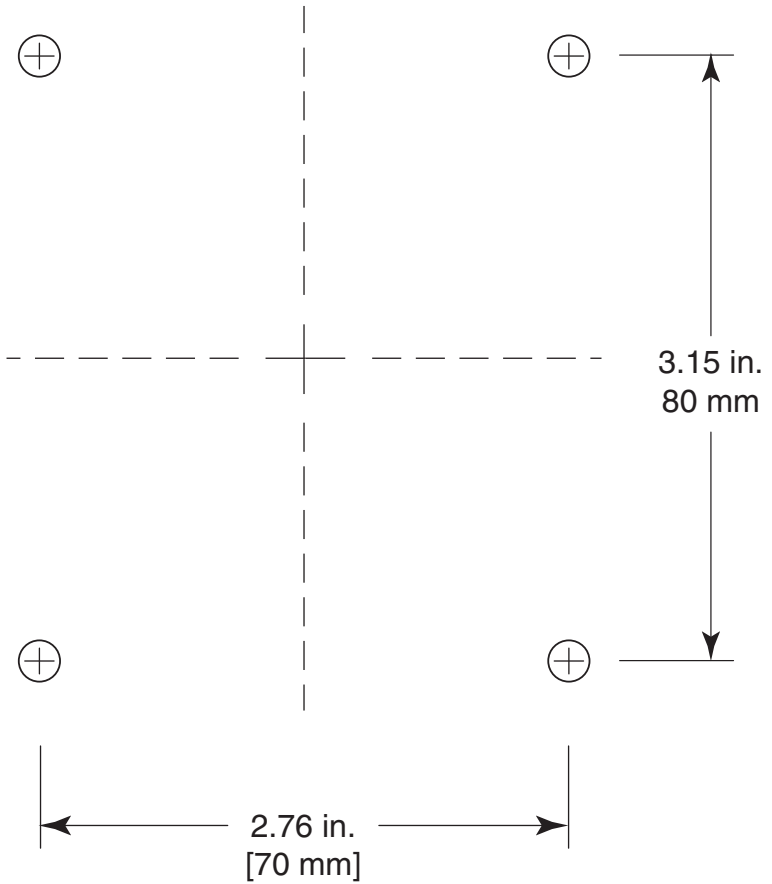

**DLE**