

The Jeti Duplex MRPM sensor provides RPM and power measurements for propeller driven models. Included with the unit is an optical sensor which performs measurements by monitoring the interruption of light through the rotating propeller, per minute.

The MRPM sensor measures the propellers current speed and performance of the propeller and provides warnings when preset parameters are exceeded.

The unit uses the 2.4GHz band to communicate, not only allowing data to be sent from the transmitter to the receiver, but also allowing the receiver in the model to transmit data back to the user. In this manner, telemetric data obtained during operation is transferred in real-time and the current state of the system can be presented on the LCD screen of the Jeti Box.

Dimensions	19 x 14 x 4 mm
Weight (with cables)	6 g
Precision	10 U / minute
Operating Temperature	-10°C → +85°C
Input voltage	3.5 – 8.4 V
Current draw	10 mA

Securing the optical sensor

The optical sensor is situated inside a metal tube, which provides the unit some protection from lateral reflections from shiny adaptors, motor housings and other reflective surfaces. Secure the optical sensor perpendicular to the propellers arc of rotation and carefully ensure that the sensor cannot under any circumstances fall into the rotating propeller at any time. The optical sensor is a very sensitive unit and should be protected from the influences of shiny or reflective surfaces and kept clear of all power supply and receiver cables.

Configuration of the MRPM Sensor Module

For parameter settings and real-time data viewing, the Jeti Box terminal must be used. The first line on the LCD screen is the identification of the sensor and the second line provides a value indicating the propeller RPM or power output. By long pushing down button R (right) a fast deletion of all measured parameters can be triggered. Fast deletion is indicated in the first line of the display by an asterix „*“.

Pressing the D ‘Down’ button of the Jeti Box accesses the menu of the RPM sensor.

MRPM MENU: Actual Value – Pressing the down button selects between displaying the following actual measured values:

Revolution – The revolutions per minute of the propeller.

Power propeller – The actual power of the propeller in watts.

MRPM MENU: MIN / MAX – Navigating the menu of the Jeti Box allows the minimum and maximum extremes of RPM and power output to be viewed. These values are automatically erased from the sensor when the configured trigger level is next exceeded. Alternatively the values can be erased manually using the the *Setting* → *Erase Data* option.

MIN/MAX RPM – Shows the minimum and maximum RPM of the propeller.

MIN/MAX Power – Shows the minimum and maximum power output of the propeller.

MRPM MENU: Setting – Using the ‘down’ button of the Jeti Box, the following options can be accessed within this menu:

Erase data – By simultaneously pressing the left and right arrow buttons, all measured parameters will be erased.

Beep High Alarm – Set the letter of the Morse code to be represented by the alarm from the transmitter module, when configured RPM or power output limits are exceeded.

Beep Low Alarm – Set the letter of the Morse code to be represented by the alarm from the transmitter module, when configured RPM or power output baselines are not being reached.

n100W – Allows setting of the N-100 value for your propeller. This metric is defined as the speed of the propeller at 100 Watts power and can usually be obtained from your propeller manufacturer. For proper operation of the sensor, this value must be entered appropriately according to your propeller. Common values can be found at www.jetimodel.com

Number of blades – Set the number of blades of your propeller

Trigger level – Sets the threshold RPM at which point maximum/minimum values should be recorded by the sensor. If this value is set to zero, then recording will begin immediately upon connection of the sensor to a power supply and any previously recorded values will be erased.

Time delay – Set a time delay between threshold values at which point recording is set to begin and the actual beginning of recording.

MRPM MENU: ALARMS – Using the down button, it is possible here to change settings for individual alarms. If an individual parameter is overshoot this will be displayed on the second line of the main screen and the alarm will be triggered.

The first tone of the alarm is generic and the second tone represents the configured letter of the Morse code for the corresponding alarm. If the alarm is set to *off*, the alarm is disabled.

Revolution High Alarm – Setting of the signal for the alarm to be sounded when the configured RPM threshold is exceeded.

Revolution Low Alarm – Setting of the signal for the alarm to be sounded when the RPM falls below the minimum threshold.

MRPM MENU: SERVICE – by pressing button D (arrow down) you will change to depiction of the firmware version and to renewal of the sensor default setting.

Factory Defaults – by simultaneous pressing of arrows R and L (right and left) the factory settings of the MRPM-AC are loaded.

MRPM-AC v. xx.xx ID xxxxx:xxxxx – product marking with firmware version and series number (ID).

Measurement Phases

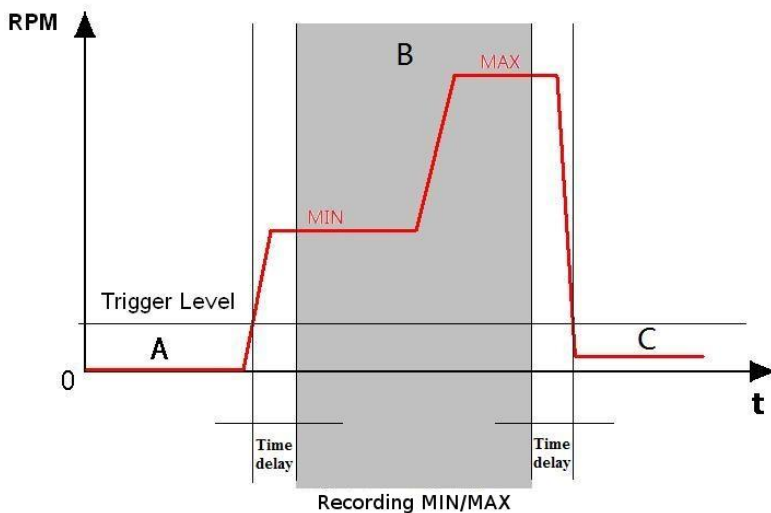

A – The currently measured speed value has not exceeded the minimum threshold. The measured values of Min/Max Power/RPM correspond to the previous session.

B – The currently measured speed value has exceeded the minimum threshold value for a time greater than the configured time delay. The previously measured values for Min/Max Power/RPM will be erased and replaced with the current measurements.

C – The currently measured speed value has remained below the minimum threshold for a time longer than the configured time delay. No measurements are recorded.

NB: Do not try to take measurements in poor lighting and avoid areas with artificial AC light sources such as light bulbs and neon lights, which can cause invalid measurements.

Firmware Update

The equipment firmware may be updated by a PC via the **converter unit JETI USB Adapter**. In the USB Adapter instructions you will find a description of the installation procedure of the USB Adapter controller as well as the update program.

Connection options for the MRPM Sensor

1. The three-wire cable with JR connector may be connected directly to the Jeti Box using the Pulse/+/- socket. A power source of 3.5-8.4V must be supplied via the Jeti Box using the +/- socket to power the module. In this configuration the RPM sensor can operate as a stand-alone mobile unit, providing measurements on the screen of the Jeti Box. No alarm signals are generated with this configuration, because these are provided by the transmitter module, which is not connected. Alerts are displayed only on the LCD screen.



2. Connect the three-wire cable with JR connector directly to the Ext. socket on the Duplex receiver. In this configuration the sensor is powered via the receiver. Switching on the transmitter and receiver allows the sensor to be configured appropriately for your power system and alarm settings to be defined.

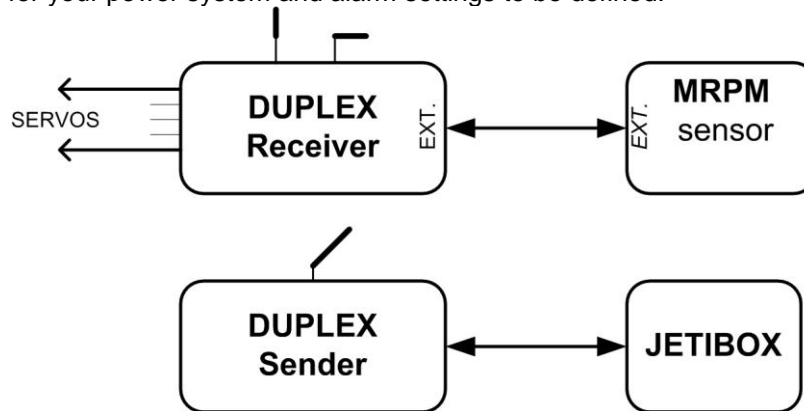

3. Connect the three-wire cable with JR connector to the Jeti Duplex Expander module and ensure that the Expander module is connected to the Duplex receiver. In this configuration the sensor is powered through the expander, which is powered through the receiver. Switching on the transmitter and receiver allows the sensor to be configured appropriately for your power system and alarm settings to be defined.

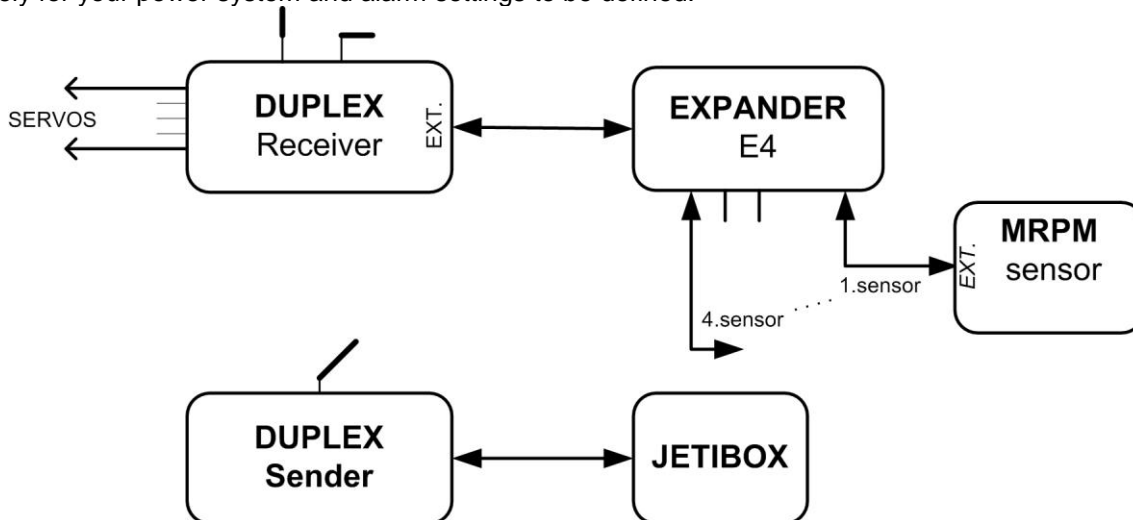

Guarantee

This product is guaranteed for a period of 24 months from the date of sale under the provision that there is no physical damage and that the unit has been used in accordance with the operating instructions. Customer service during the warranty period and thereafter is carried out by the manufacturer.

We wish you a pleasant flight: Jeti Model S.R.O Pribor, www.jetimodel.cz

Menu navigation via the Jeti Box for MRPM Sensor

