

ELECTRO SAILPLANE

SUPER SPORT 2,35



Manufactured by:

TOPMODEL CZ

679 05 HABRŮVKA 100 - CZECH REPUBLIC

www.topmodelcz.cz

e-mail: info@topmodelcz.cz

Order N°: 020117

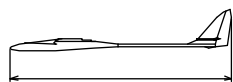

1385mm

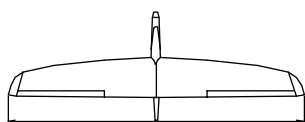

2350mm

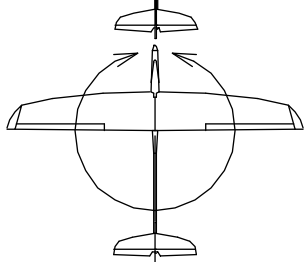

50dm²
30-34g/dm²



1,5 - 1,7kg

Radio system you'll need :

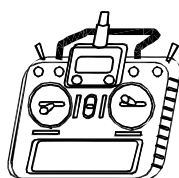

5channel
with
6 servos

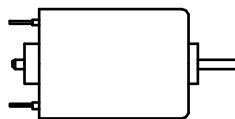

MVVS 3,5/960

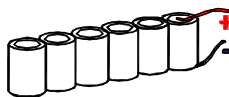

3S Lixx 2,2-2,6Ah



AG

*Není-li uvedeno jinak, všechny
neoznačené míry jsou v milimetrech*
UNLES STATED, ALL DIMENSIONS
ARE IN MILIMETERS

Part #	Part name	Material/dimensions	Loose	In bag
	building instruction		01	
1	fuselage	fibreglass	01	
1-1	engine mount	fibreglass 3mm		01
1-2	servo tray	plywood 4x56x60mm		01
1-3	link support	balsa 5x10x56		01
1-CT	cutting template	plywood 3mm	01	
2	wing	balsa assembly	02	
2-1	aileron	balsa	02	
2-11	flap	balsa	02	
2-2	wing fixing screw	M4x20		02
2-21	centering pin	fibreglass Ø3x30mm		01
2-25	centering pin	fibreglass Ø4x75mm		02
2-3	wing nut	AL M4		02
2-31	nut mount	plywood 3x23x53		01
2-4	servo mount	polyurethan 12mm		08
2-41	wing servo cover	ABS plastic		04
2-5	aileron&flap pushrod	steel Ø1,8mm		04
2-6	clevis	MPJ 2110		04
2-8	aileron horn	fibreglass plate 1,5mm		02
2-81	flap horn	fibreglas plate 1,5mm		02
24	wing joiner	Al+carbon Ø10x180mm		01
3	horizontal stabilazer	balsa assembly		02
3-21	centering pin	fibreglass Ø3x70mm		01
3-3	elevator joiner	fibreglass Ø4x150mm		01
3-5	elevator link	balsa Ø10x770mm	01	
3-5F	elevator link	steel Ø2x180mm		01
3-5N	thread	2m		01
3-5R	elevator link	steel M2x180mm		01
3-6F	threaded rod tip M2	MPJ 2762		01
3-6R	clevis	metal M2, nut M2		01+01
3-8	elevator horn	fibreglass plate 2mm		01
4	fin	balsa assembly	01	
4-3	closing strip	plywood 6mm		01
4-5	ruder link	bowden Ø3x900mm, steel Ø1,2x1000mm	01 01	
4-6	threaded rod tip M2	MPJ 2762		01
4-8	rudder horn	fibreglass plate 1,5mm		01
6	canopy	fibreglass	01	
6-2	canopy fixing	fibreglass Ø2x200mm		01
6-21	mount	plywood 1x6x12mm		02
7	stickers		04	
11	pinned hinge	MS0124028		02

RECOMMENDED EQUIPMENT				
		Pieces		Item No. www.topmodelcz.cz
transmitter	5 channel			
reciever	6-7 channel			
servo	HS-82MG	2	for ailerons & flaps	1HI7297
	HS-485HB	2	for elevator & rudder	1HI3085
motor	MVVS 3,5/960	1		2045
controller	SPIN 44	1		1RC23203
spinner	turbo Ø40;5;8	1		0201559
propeller	CAM Carbon 12x6,5"	1		723446
battery	Hyperion G3 VX-3S 2600mAh	1		HP-LG335-2600-3S

ATTENTION!

This model construction kit is not a toy and is not suitable for children under the age of 14. Incorrect use of this model could cause material damage or personal injury. You are fully responsible for your actions when you use this model.

Fly at a safe distance from occupied zones. Before switching on the radio, be sure, that no one else is using the same frequency as you !

Before first take-off check up please the center of gravity, the sense and size of the control surface angle and if model aeroplane parts aren't crooked. The reparation is possible through the use of hot-air dryer.

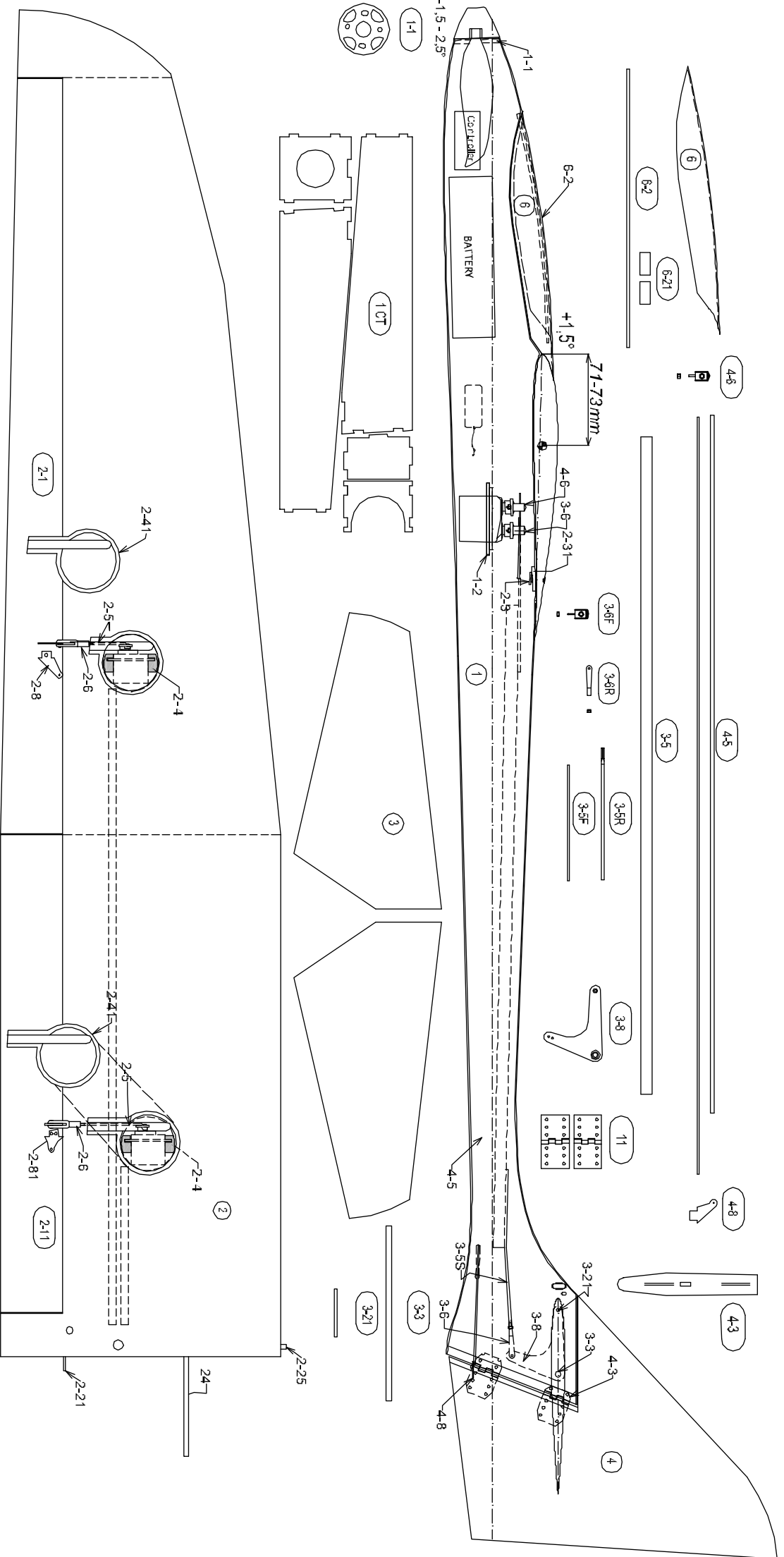

super SYRBY 2,35

©XI. 2012 TOPMODEL CZ Manufactured by TOPMODEL CZ s.r.o. 679 05 HABRŮVKA 100
 www.topmodel.cz e-mail: info@topmodel.cz

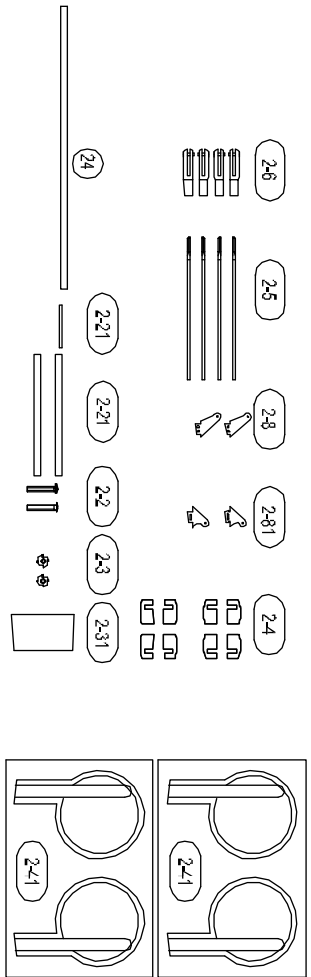

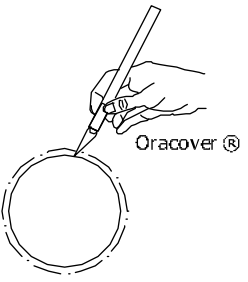

SPODNÍ STRANA BOTTOM

2

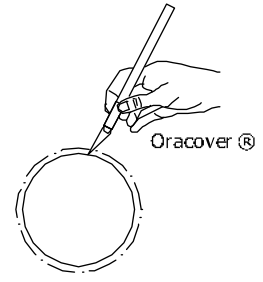

Oracover®
spodní strana
bottom

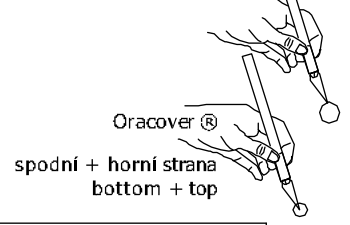

Oracover®
spodní + horní strana
bottom + top

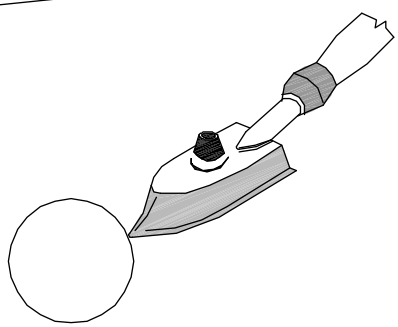

SPODNÍ STRANA BOTTOM

2

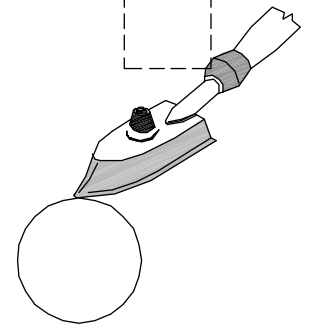

SPODNÍ STRANA BOTTOM

2

krok 1.
step 1.

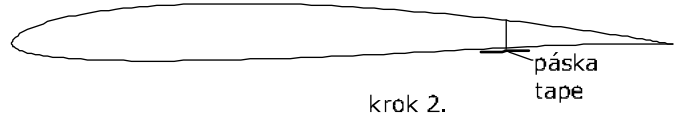

páska
tape

krok 2.
step 2.

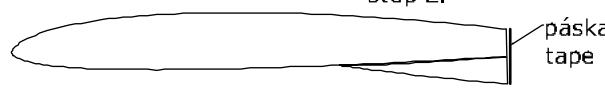

páska 2
tape



2-11

VRCHNÍ STRANA TOP

2

krok 1.
step 1.

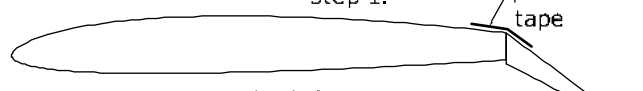

páska
tape

krok 2.
step 2.

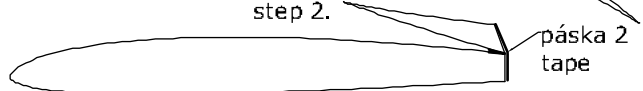

páska 2
tape



2-1

2

2-25

2-21

2

2-21

~180mm - 2x

pro serva klapek
for flaps servo

~600mm - 2x

pro serva křídélek
for ailerons servo

~180mm

~600mm

SPODNÍ STRANA
BOTTOM

2

2-4

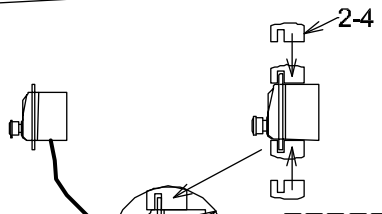

SPODNÍ STRANA
BOTTOM

②

NEUTRAL

SPODNÍ STRANA
BOTTOM

②

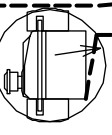

SPODNÍ STRANA
BOTTOM

②

Ø1,5 pro 2-81
Ø1,5 for 2-81

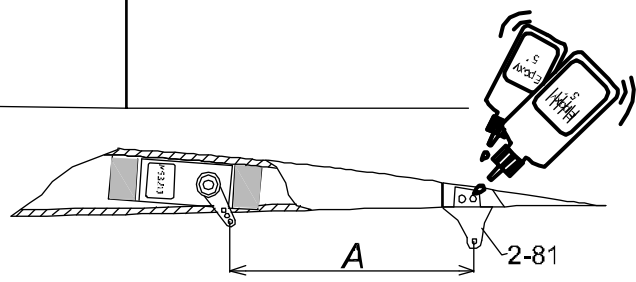
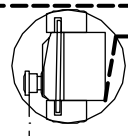

"Z"

2-5

!!! A=Á !!!

A

2-6

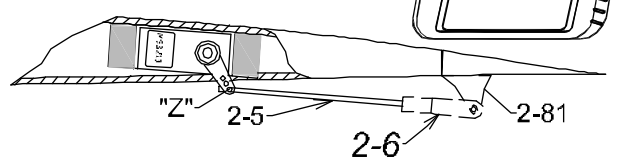
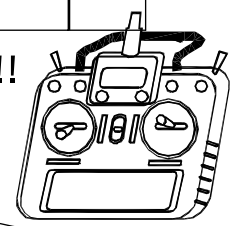

"Z"

2-5

2-6

2-81

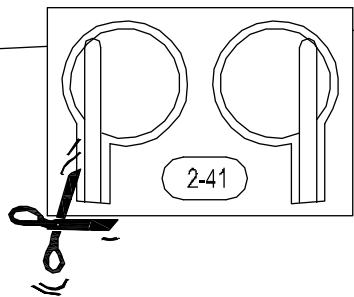

SPODNÍ STRANA
BOTTOM

②

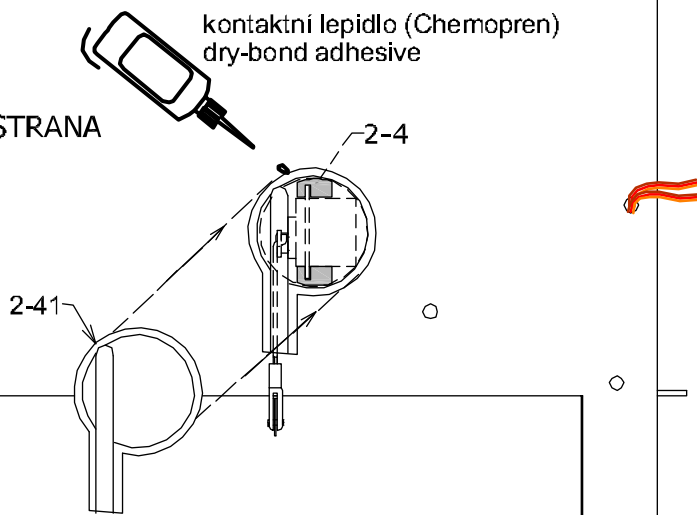

kontaktní lepidlo (Chemopren)
dry-bond adhesive

SPODNÍ STRANA
BOTTOM

②

Ø1,5 pro 2-8
Ø1,5 for 2-8

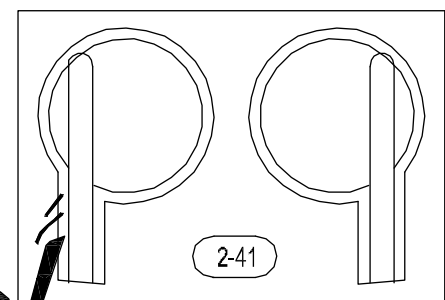
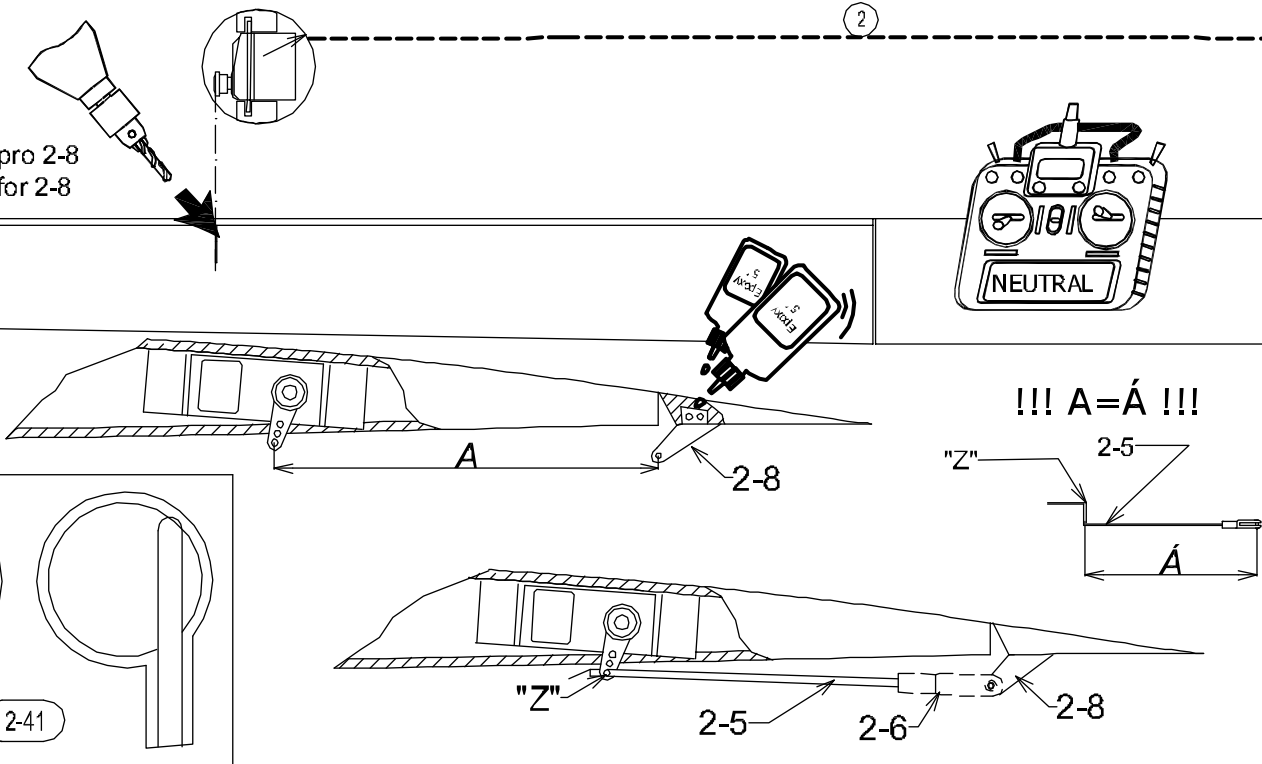

SPODNÍ STRANA
BOTTOM

②

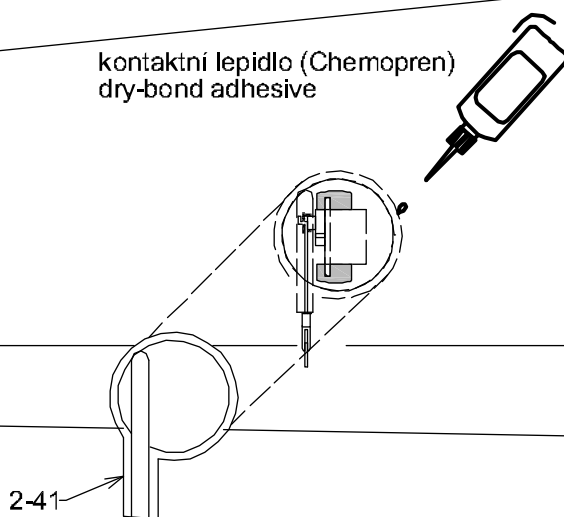

kontaktní lepidlo (Chemopren)
dry-bond adhesive

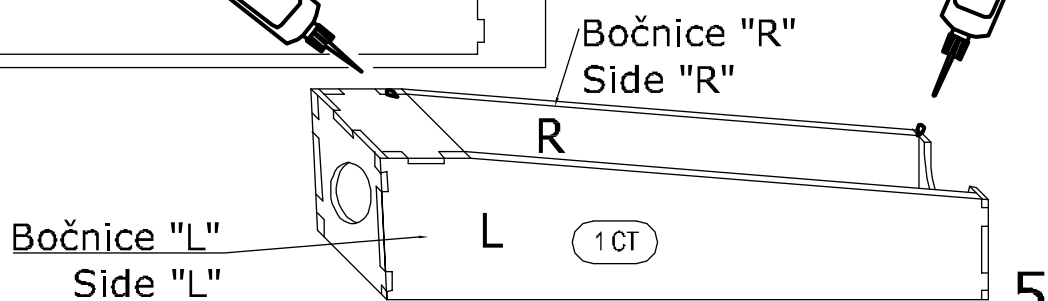
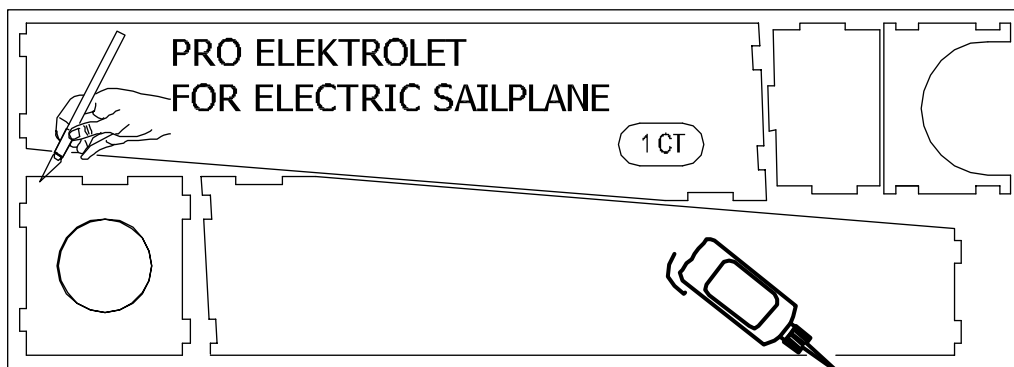
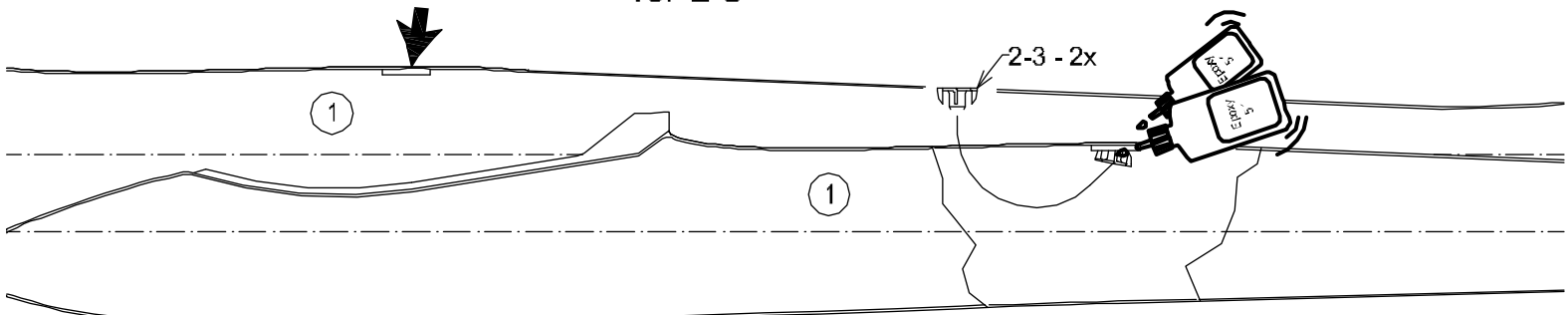
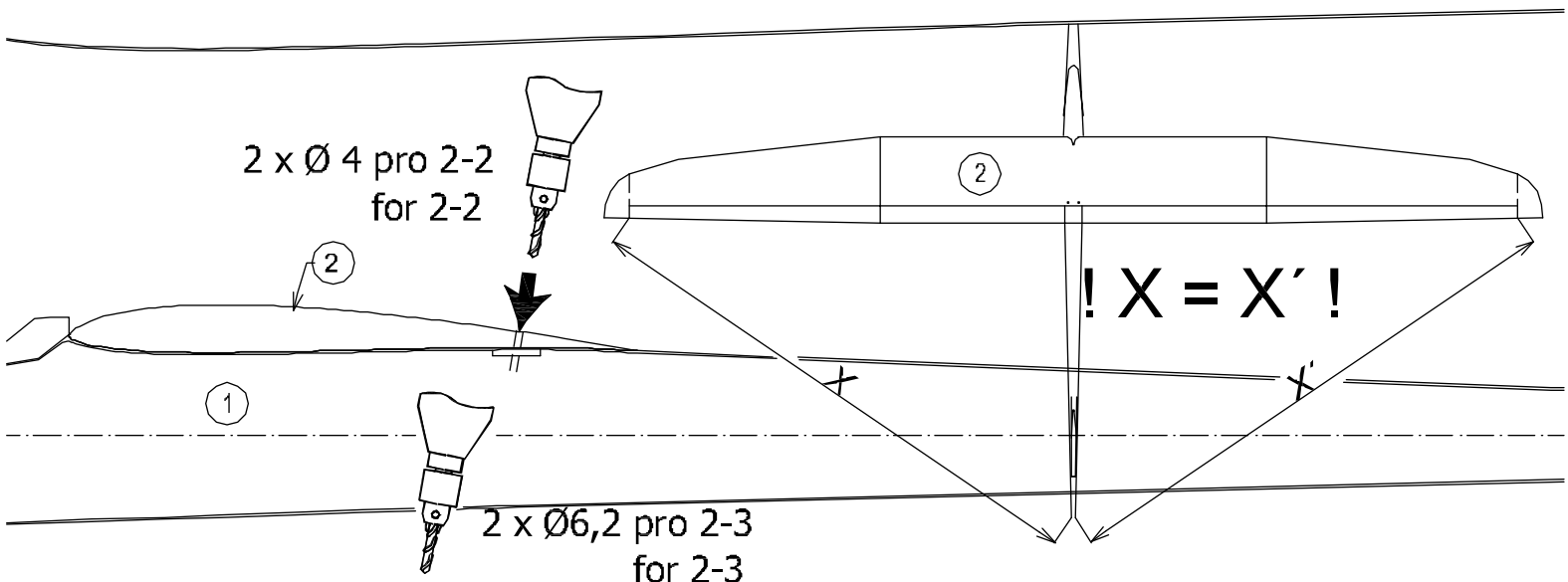
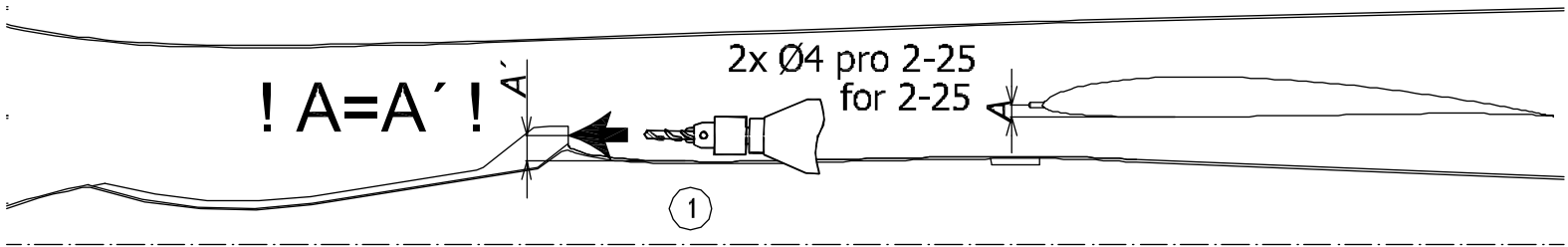
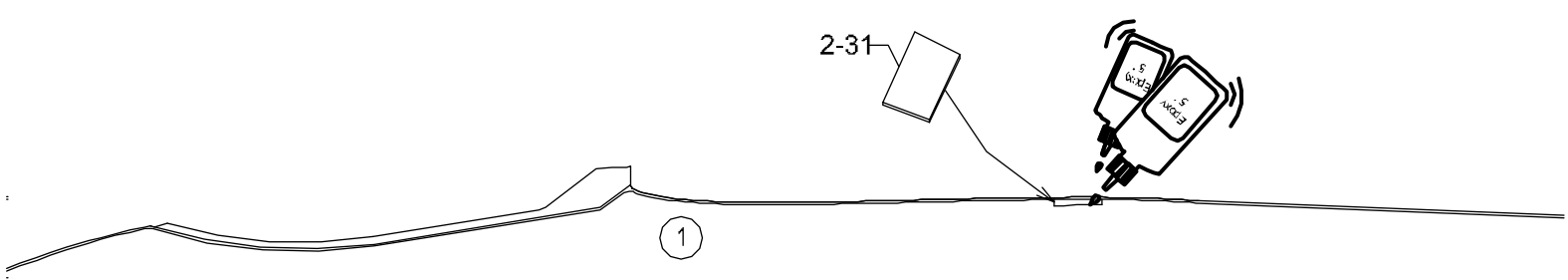

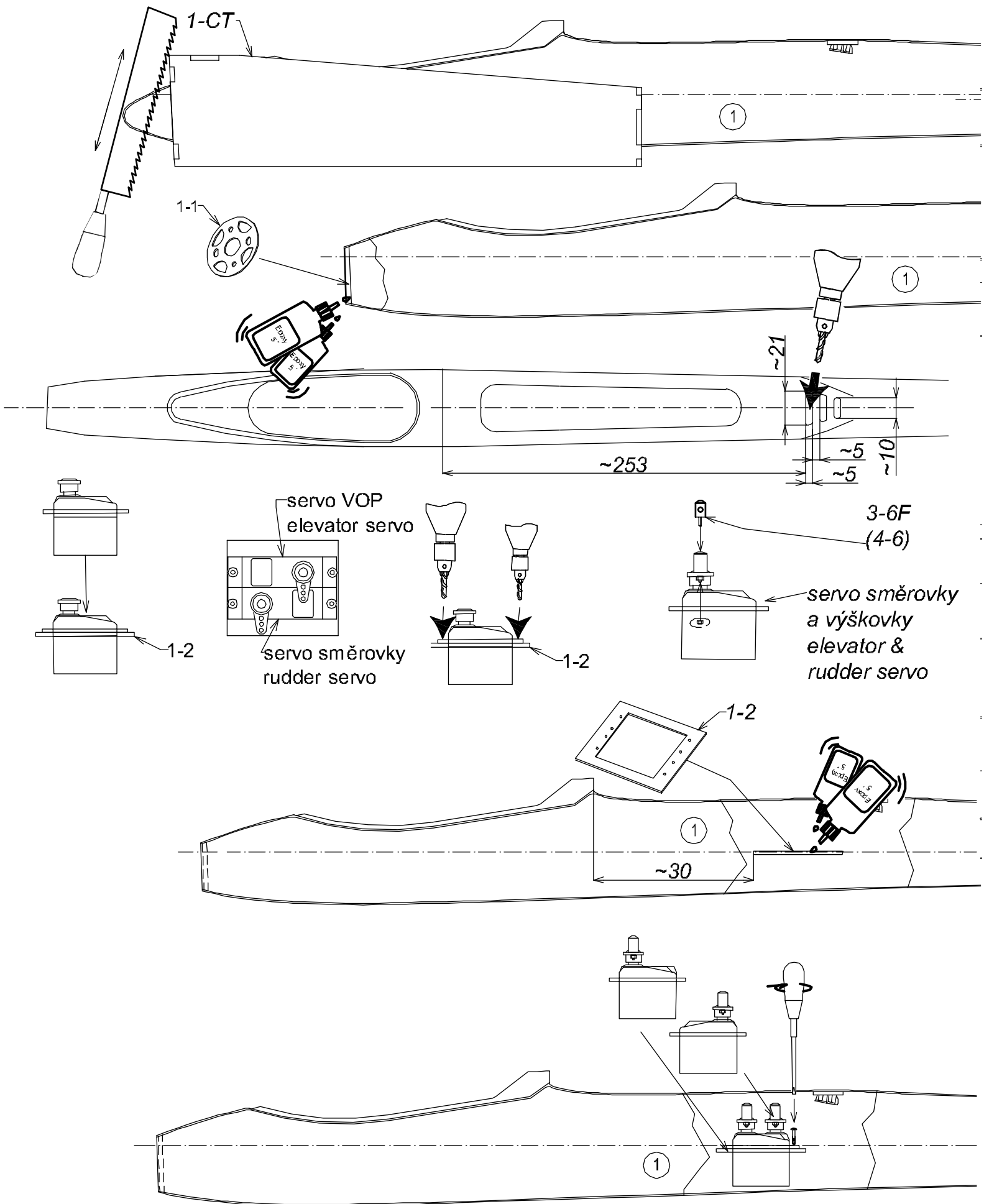

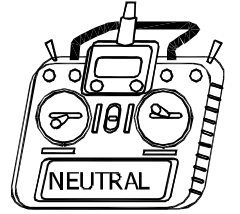
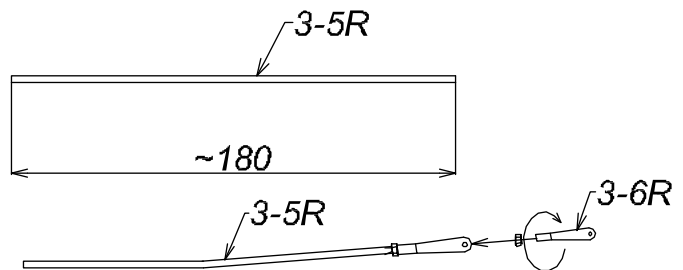
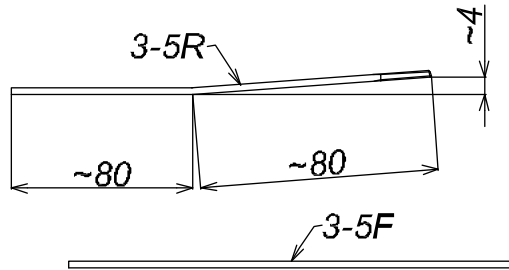
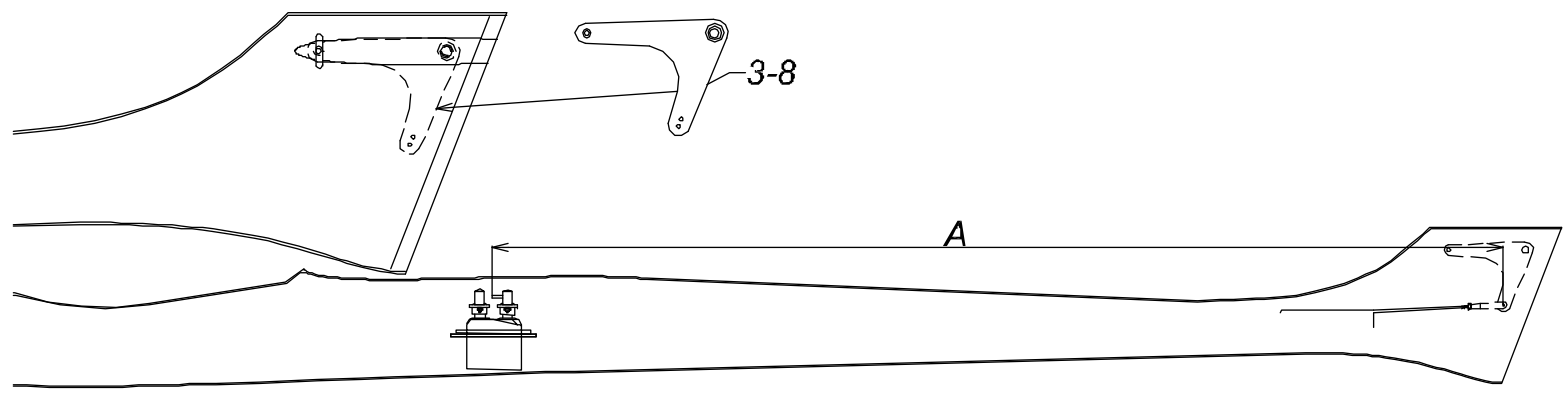

omostat niti
bind with string

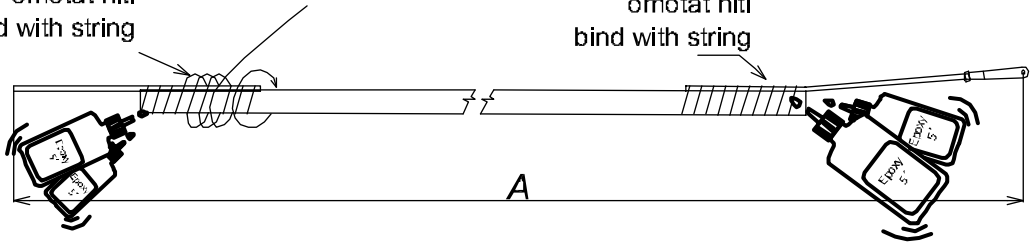

A = A

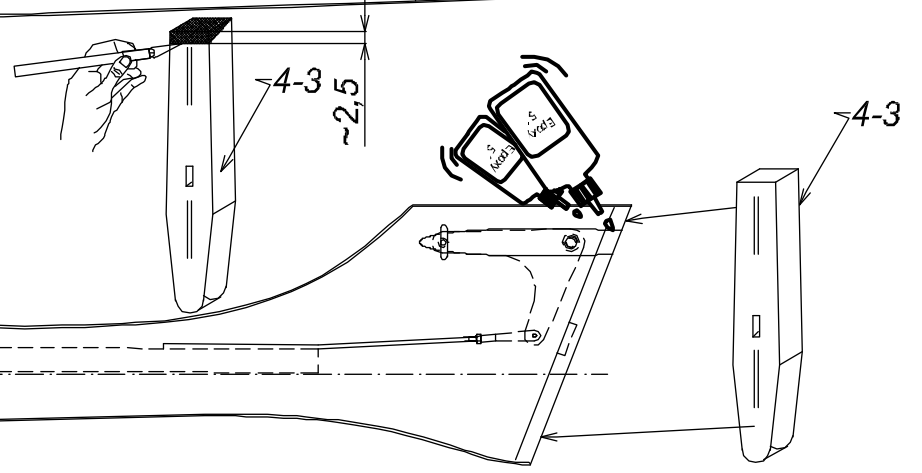
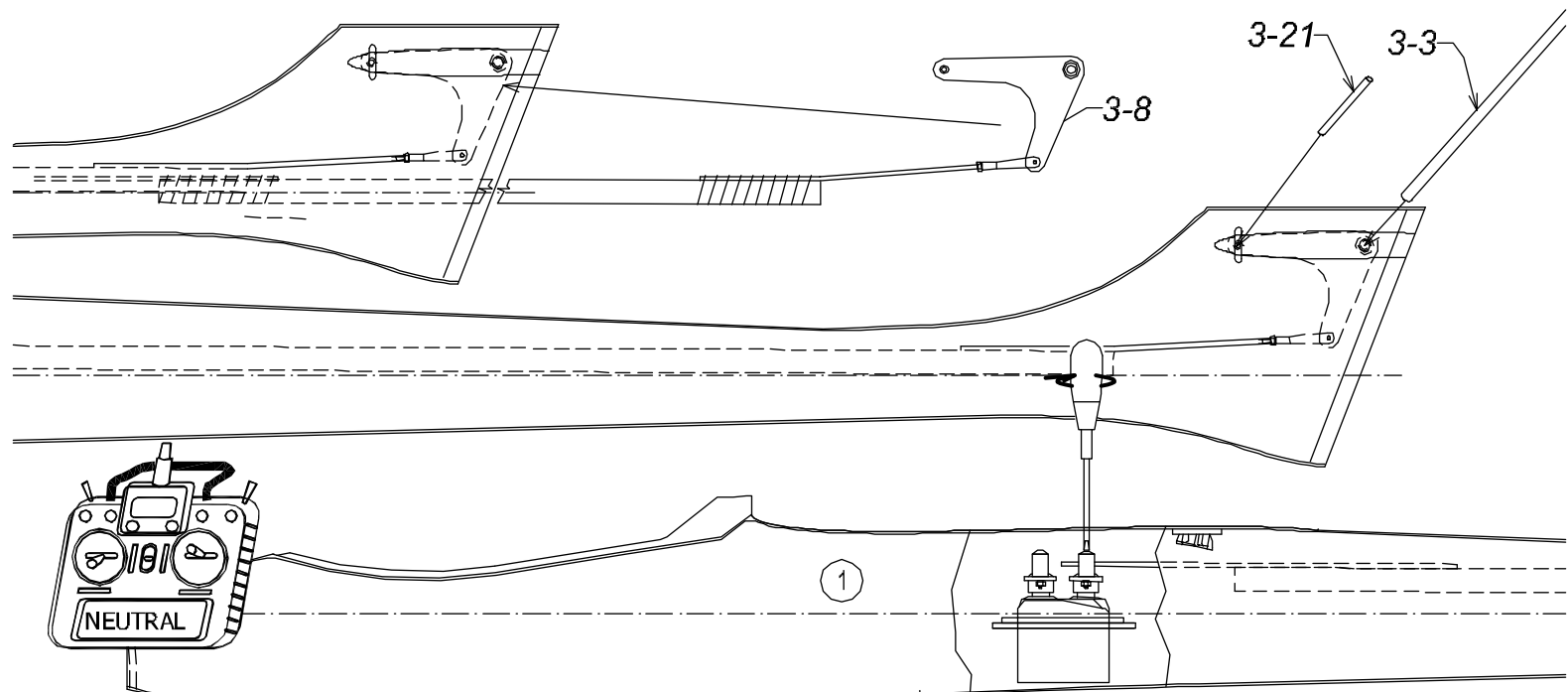

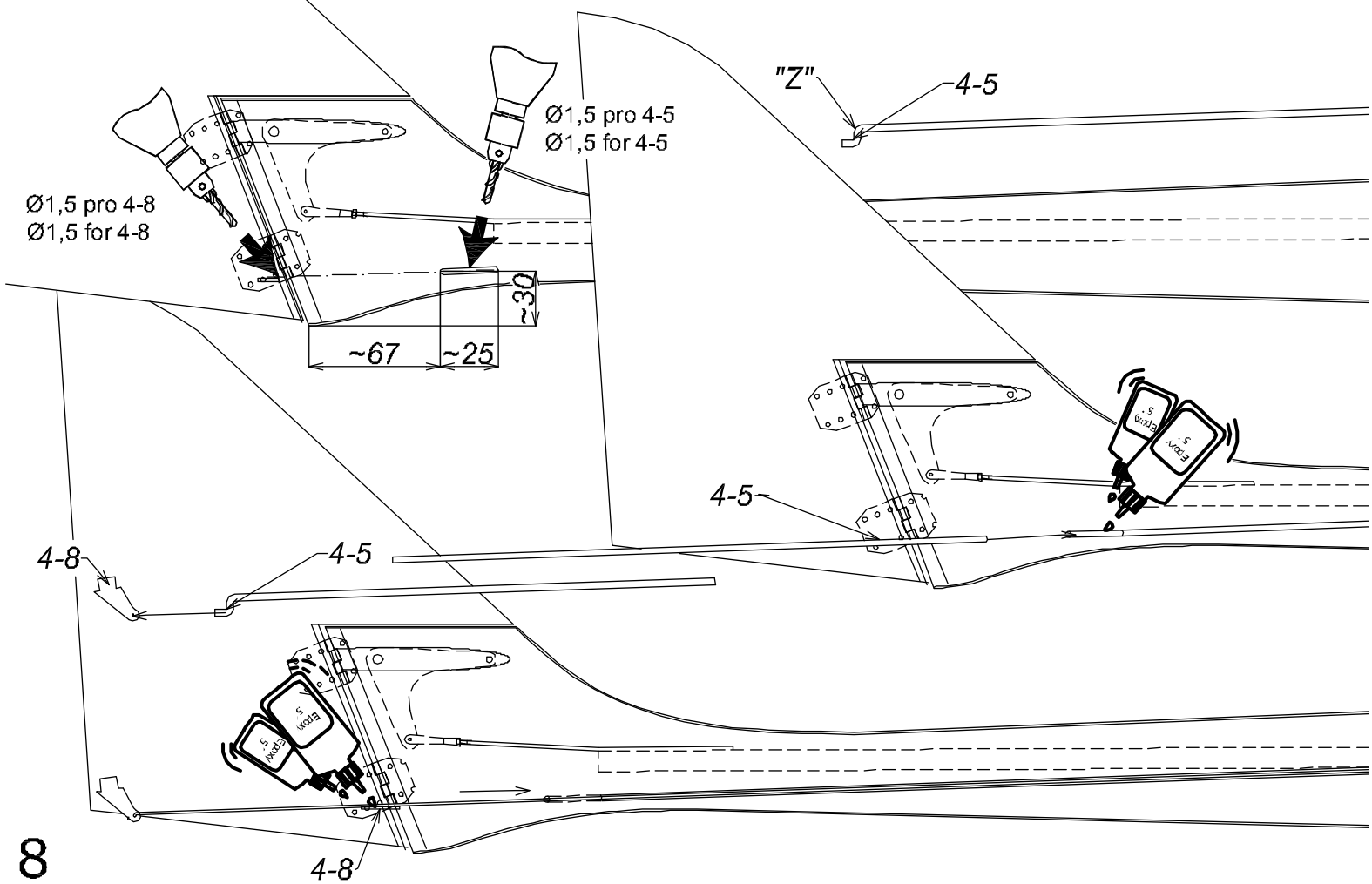
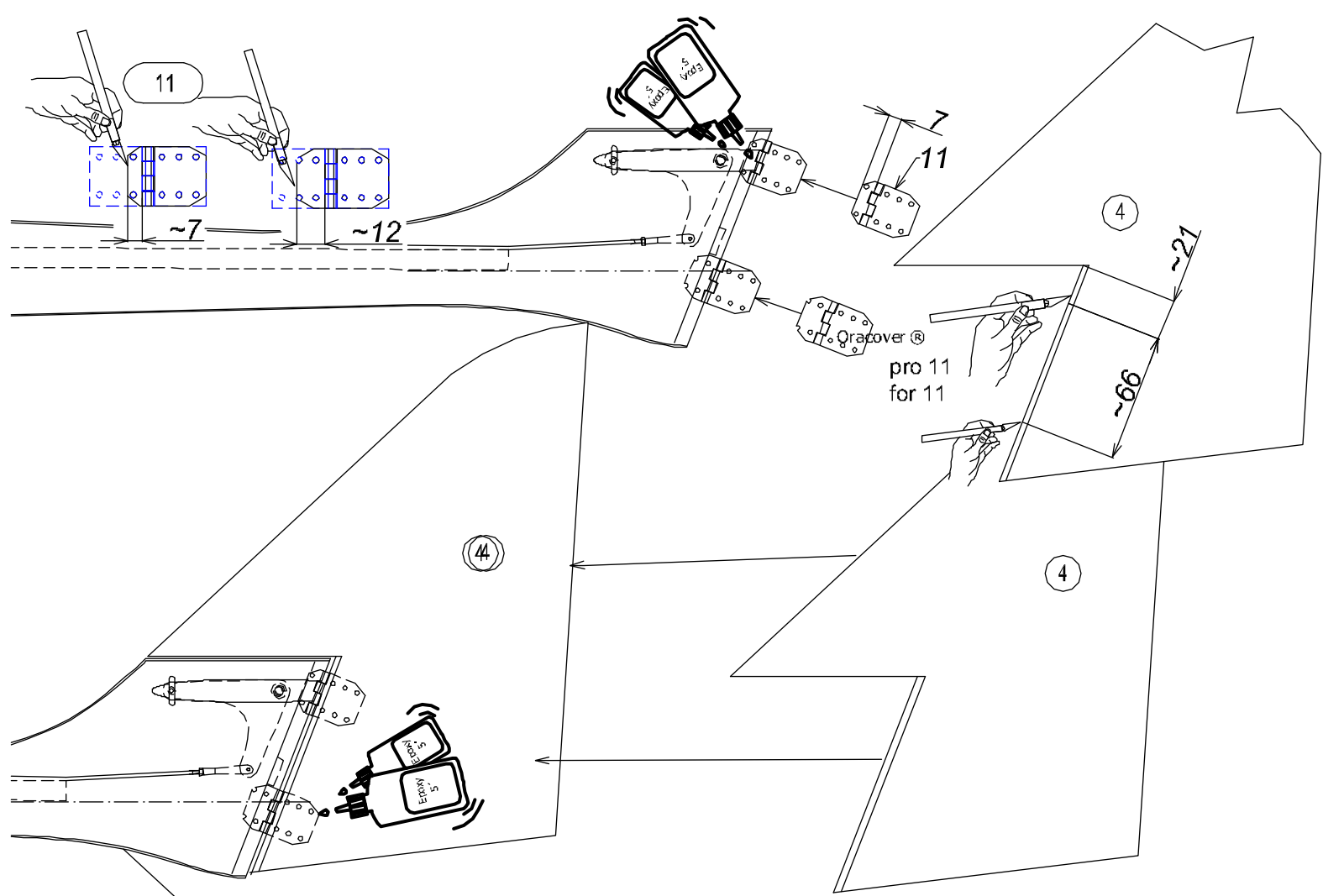

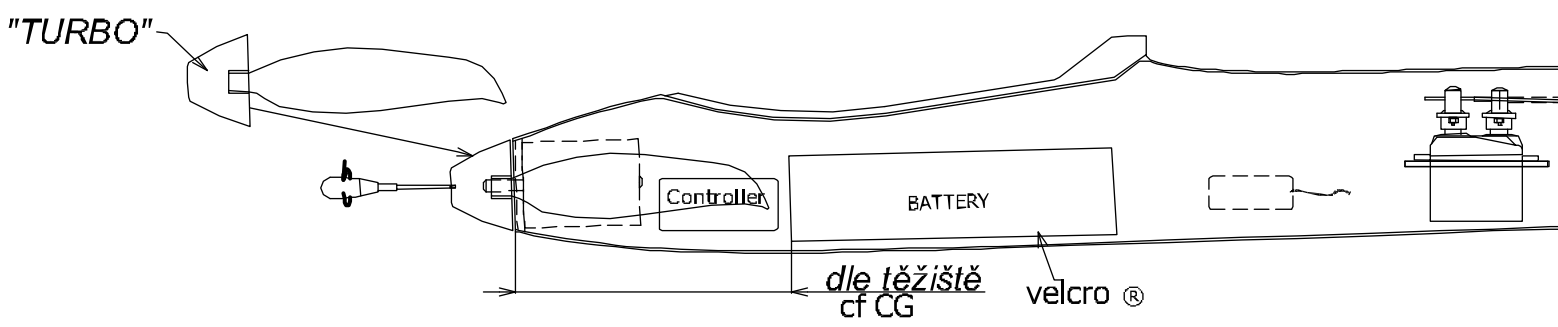
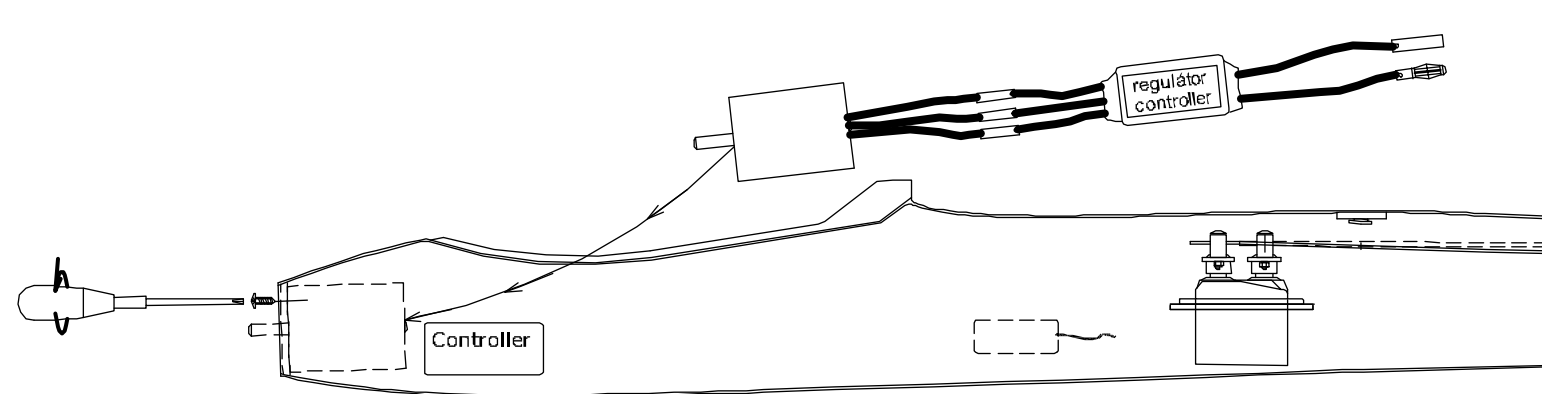
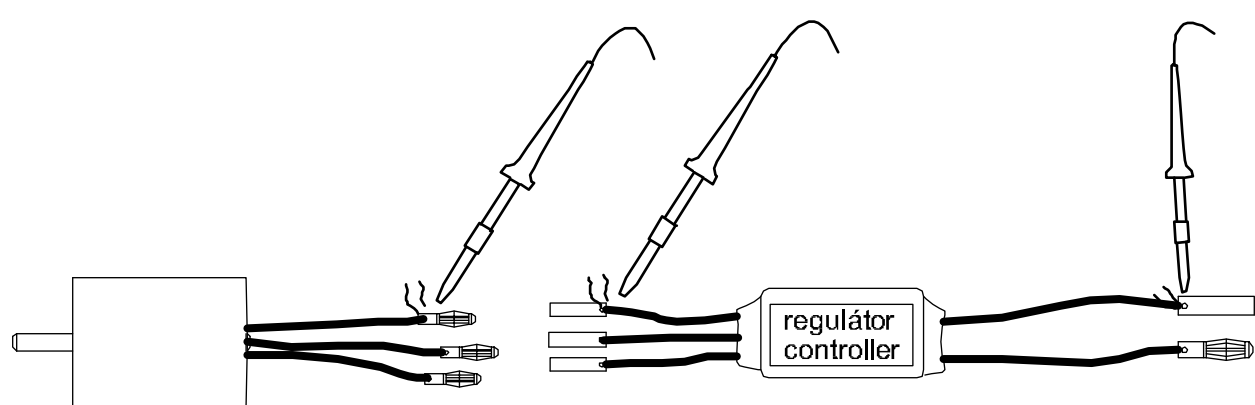
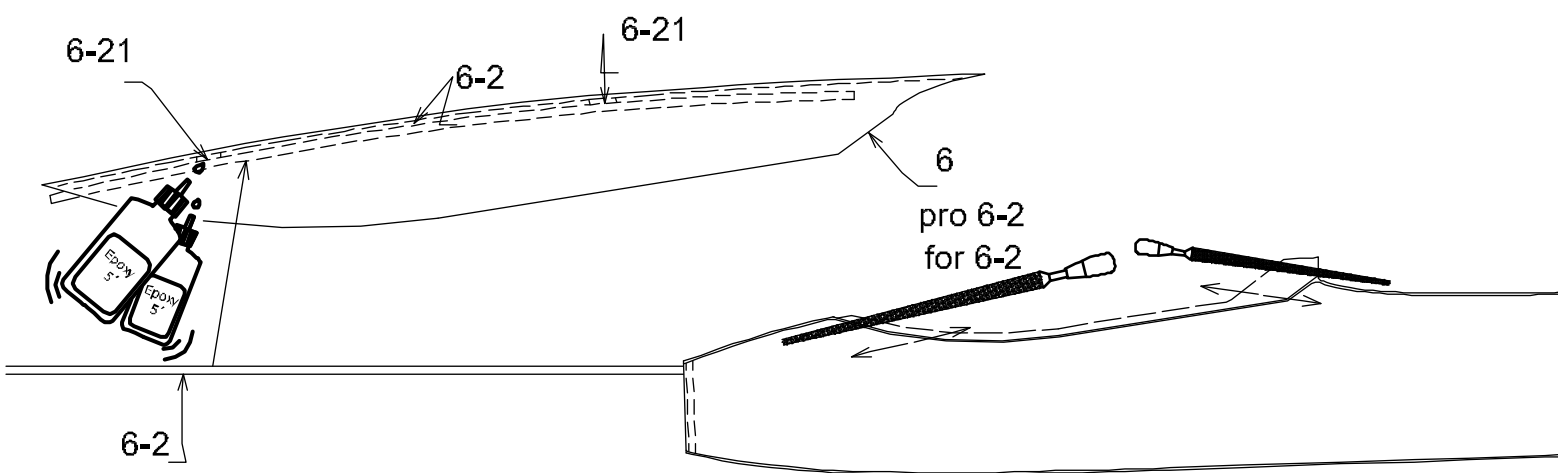
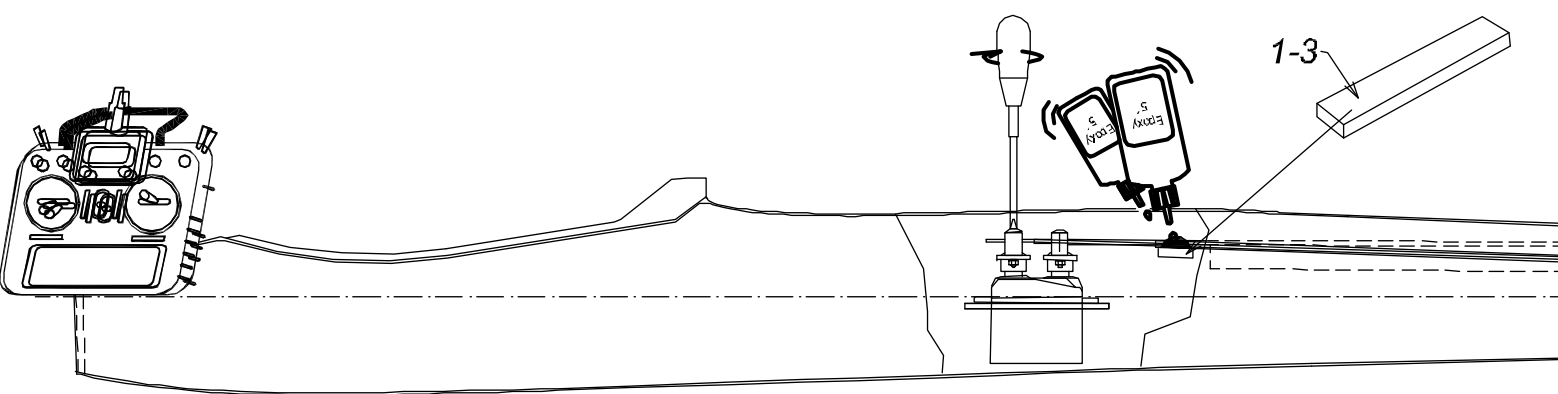

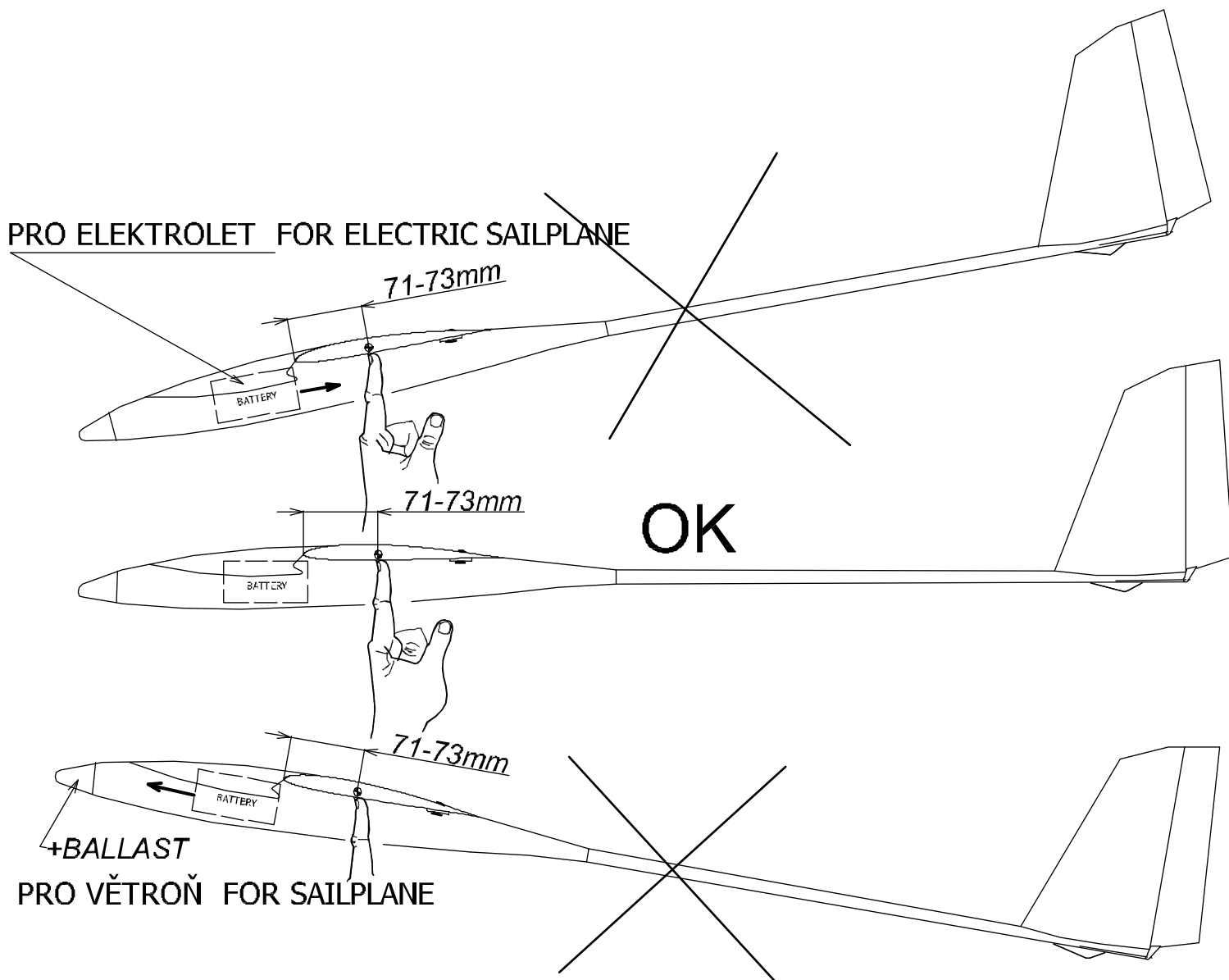

Recommended rudder angles :

- Ailerons: up 18 °
down 11 °
- Elevator: Up 8 °
down 8 °
- Rudder: 25 °

Settings for thermal flying:

- Ailerons works as flap: down 1-1.5 °
- Flap: down 2 °

Settings for landing:

- Flap works as airbrakes (for landing): down 80 °
- Ailerons works as airbrakes (for landing): up 17 °
- Elevator for landing: -5 ° (suppression - compensation of overturning moment for flaps)